

GSX-R1000

OWNER'S MANUAL

This owner's manual contains important safety information. Please read it carefully.



Way of Life!

California Proposition 65 Warning

▲ WARNING

Engine exhaust, some of its constituents, and certain product components contain or emit chemicals known to the State of California to cause cancer and birth defects or other reproductive harm.

This manual should be considered a permanent part of the motorcycle and should remain with the motorcycle when resold or otherwise transferred to a new owner or operator. The manual contains important safety information and instructions which should be read carefully before operating the motorcycle.

IMPORTANT

WARNING/CAUTION/NOTE

Please read this manual and follow its instructions carefully. To emphasize special information, the symbol ▲ and the words WARNING, CAUTION and NOTE have special meanings. Pay special attention to the messages highlighted by these signal words:

▲ WARNING

Indicates a potential hazard that could result in death or injury.

CAUTION

Indicates a potential hazard that could result in motorcycle damage.

NOTE: Indicates special information to make maintenance easier or instructions clearer.

WARNINGS and CAUTIONS are arranged like this:

▲ WARNING-or-CAUTION

The first part will describe a **POTENTIAL HAZARD** and **WHAT CAN HAPPEN** if you ignore the **WARNING** or **CAUTION**.

The second part will describe **HOW TO AVOID THE HAZARD**.

FOREWORD

Motorcycling is one of the most exhilarating sports and to ensure your riding enjoyment, you should become thoroughly familiar with the information presented in this Owner's Manual before riding the motorcycle.

The proper care and maintenance that your motorcycle requires is outlined in this manual. By following these instructions explicitly, you will ensure a long trouble-free operating life for your motorcycle. This motorcycle also conforms to the U.S. Environmental Protection Agency emission regulations which apply to new motorcycles. The proper adjustment of engine components is necessary for this motorcycle to comply with the EPA regulations. Therefore, please follow the maintenance instructions closely to ensure emission compliance. Your Suzuki dealer has experienced technicians that are trained to provide your machine with the best possible service with the right tools and equipment.

All information, illustrations and specifications contained in this manual are based on the latest product information available at the time of publication. Due to improvements or other changes, there may be some discrepancies between information in this manual and your motorcycle. Suzuki reserves the right to make production changes at any time, without notice and without incurring any obligation to make the same or similar changes to vehicles previously built or sold.

Suzuki Motor Corporation believes in conservation and protection of Earth's natural resources. To that end, we encourage every vehicle owner to recycle, trade in, or properly dispose of, as appropriate, used motor oil, coolant, and other fluids, batteries and tires.



SUZUKI MOTOR CORPORATION

© COPYRIGHT SUZUKI MOTOR
CORPORATION 2008

TABLE OF CONTENTS

THE SPORT OF MOTORCYCLING

1

FUEL, ENGINE OIL AND COOLANT RECOMMENDATIONS

2

CONTROLS, EQUIPMENT AND ADJUSTMENTS

3

BREAK-IN AND INSPECTION BEFORE RIDING

4

RIDING TIPS

5

ACCESSORY USE AND MOTORCYCLE LOADING

6

INSPECTION AND MAINTENANCE

7

TROUBLESHOOTING

8

STORAGE PROCEDURE AND MOTORCYCLE CLEANING

9

CONSUMER INFORMATION

10

SPECIFICATIONS

INDEX

PartShark.com
877-999-5686

THE SPORT OF MOTORCYCLING

MOST ACCIDENTS CAN BE AVOIDED	1-2
IF YOU DON'T HAVE A HELMET, BUY A HELMET AND WEAR IT	
EVERY TIME YOU RIDE	1-2
IF A COLLISION IS IMMINENT, DO SOMETHING	1-3
SPECIAL SITUATIONS REQUIRE SPECIAL CARE	1-4
KNOW YOUR LIMITS	1-4
BE EXTRA SAFETY-CONSCIOUS ON BAD WEATHER DAYS	1-5
PRACTICE AWAY FROM TRAFFIC	1-5
INSPECTION BEFORE RIDING	1-5
ACCESSORIES AND LOADING	1-5
CARRYING A PASSENGER	1-6
MOTORCYCLE SAFETY FOUNDATION'S	
"RIDING TIPS AND PRACTICE GUIDE" HANDBOOK	
(FOR OWNERS IN USA)	1-6
BE STREET SMART	1-6
CONCLUSION	1-6

THE SPORT OF MOTORCYCLING

Your motorcycle and this owner's manual have been designed by people like you who enjoy motorcycling. People become motorcyclists for many reasons. For starters, street riding is fun and invigorating. But no matter why you became a motorcyclist, or how experienced you are, you will eventually face some challenging situations.

In preparing for these challenges, you will be fine-tuning your coordination, concentration, and attitude. Learning the skills and strategies associated with motorcycling is the basis for safely participating in this sport. Many motorcyclists find that as they become better riders, they also get more enjoyment from the freedom unique to motorcycling.

Please remember:

MOST ACCIDENTS CAN BE AVOIDED

The most common type of motorcycle accident in the U.S. occurs when a car traveling towards a motorcycle turns left in front of the motorcycle. Is that because other drivers are out to get motorcyclists? No. Other drivers simply don't always notice motorcyclists.

Ride defensively. Wise motorcyclists use a strategy of assuming they are invisible to other drivers, even in broad daylight. Pay careful attention to other motorists, especially at intersections, because they may not be paying attention to you. Select a lane position that gives you the best view of others, and other motorists the best view of you. Wear bright, reflective clothing. Put reflective strips on your helmet.

IF YOU DON'T HAVE A HELMET, BUY A HELMET AND WEAR IT EVERY TIME YOU RIDE

Most accidents occur within a few miles of home, and almost half occur at speeds of less than 30 mph. So even if you're just going on a quick errand, be prepared—strap on your helmet before you take off.

Helmets do not reduce essential vision or hearing. Generally, helmets do not cause or intensify injury if you crash. Helmets simply help your skull protect your intelligence, your memory, your personality, and your life.

Your eyesight is equally valuable. Wearing suitable eye protection can help keep your vision unblurred by the wind and save your eyes from airborne hazards like bugs, dirt, or pebbles kicked up by tires.

IF A COLLISION IS IMMINENT, DO SOMETHING

Many riders fear locking up their brakes or haven't learned to swerve to avoid an accident. Many inexperienced riders (and too many seasoned riders) use only their rear brake in an emergency, resulting in unnecessary impacts in some cases and unnecessarily high impact speeds in other cases. Your rear brake can only provide about 30% of your motorcycle's potential stopping power. The front and rear brakes can and should be used together to maximize braking effectiveness.

Experienced motorcyclists learn to "cover" the front brake lever by lightly resting a couple of fingers over the lever when riding in traffic and near intersections to give their reaction time a head start.

Emergency stopping and swerving are techniques that you should practice and master before you find yourself in an emergency situation. The best place to practice such techniques is in a controlled environment such as the Motorcycle Safety Foundation's (MSF) rider training courses. The MSF's Motorcycle Rider Courses (fundamental techniques) and Experienced Rider Courses (advanced strategies) present hands-on instruction of the basic principles of motorcycling and a variety of accident-avoidance maneuvers. Even a seasoned motorcyclist can improve his or her riding skills, and pick up a few new skills, through these courses. Some insurance companies even offer discounts to course graduates.

SPECIAL SITUATIONS REQUIRE SPECIAL CARE

Of course, there are some times when full-force braking is not the correct technique. When the road surface is wet, loose, or rough, you should brake with care. When you're leaned over in a corner, avoid braking. Straighten up before braking. Better yet, slow down before entering the corner.

In these situations, the traction available between your tires and the road surface is limited. Over-braking when traction is limited will cause your tires to skid, possibly resulting in loss of directional control or causing you and your motorcycle to fall over.

KNOW YOUR LIMITS

Always ride within the boundaries of your own skills. Knowing these limits and staying within them will help you avoid accidents.

A major cause of accidents involving only a motorcycle (and no cars) is going too fast through a turn. Before entering a turn, select an appropriately low cornering speed.

Even on straight roads, ride at a speed that is appropriate for the traffic, visibility and road conditions, your motorcycle, and your experience.

Riding a motorcycle safely requires that your mental and physical skills are fully part of the experience. You should not attempt to operate a motor vehicle, especially one with two wheels, if you are tired or under the influence of alcohol or other drugs. Alcohol, illegal drugs, and even some prescription and over-the-counter drugs can cause drowsiness, loss of coordination, loss of balance, and especially the loss of good judgment. If you are tired or under the influence of alcohol or other drugs, **PLEASE DO NOT RIDE** your motorcycle.

BE EXTRA SAFETY-CONSCIOUS ON BAD WEATHER DAYS

Riding on bad weather days, especially wet ones, requires extra caution. Braking distances increase on a rainy day. Stay off the painted surface marks, man-hole covers, and greasy-appearing areas, as they can be especially slippery. Use extra caution at railway crossings and on metal gratings and bridges. When it starts to rain, any oil or grease on the road rises to the surface of the water. Pull over and wait a few minutes until this oil film is washed away before riding. Whenever in doubt about road conditions, slow down!

PRACTICE AWAY FROM TRAFFIC

Your riding skill and your mechanical knowledge form the foundation for safe riding practices. We suggest that you practice riding your motorcycle in a non-traffic situation until you are thoroughly familiar with your machine and its controls. Again, consider taking one of the MSF's Rider Courses. Even experts will be pleased with the caliber of the information presented in these courses. As the MSF says: "The more you know, the better it gets!"

INSPECTION BEFORE RIDING

Review the instructions in the "INSPECTION BEFORE RIDING" section of this manual. Perform an entire pre-ride inspection before you head out on the road. Spending a few minutes preparing your machine for a ride can help prevent accidents due to mechanical failure or costly, inconvenient breakdowns far from home.

ACCESSORIES AND LOADING

The accessories you use with your motorcycle and the manner in which you load your gear onto the bike might create hazards. Aerodynamics, handling, balance, and cornering clearance can suffer, and the suspension and tires can be overloaded. Read the "ACCESSORY USE AND MOTORCYCLE LOADING" section.

CARRYING A PASSENGER

Carrying a passenger, when done correctly, is a great way to share the joy of motorcycling. You will have to alter your riding style somewhat since the extra weight of a passenger will affect handling and braking. You may also need to adjust tire pressures and suspension; please refer to the Tire Pressure and Loading section and the Suspension section for more details.

A passenger needs the same protection that you do, including a helmet and proper clothing. The passenger should not wear long shoe laces or loose pants that could get caught in the wheel or the chain. Passengers must be tall enough that their feet reach the footrests.

MOTORCYCLE SAFETY FOUNDATION'S "RIDING TIPS AND PRACTICE GUIDE" HANDBOOK (FOR OWNERS IN USA)

This special handbook, supplied with your owner's manual, contains a variety of safety tips, helpful hints, and practice exercises. This manual can increase your riding enjoyment and safety. You should read it thoroughly.

BE STREET SMART

Always heed speed limits, local laws, and the basic rules of the road. Set a good example for others by demonstrating a courteous attitude and a responsible riding style.

CONCLUSION

Traffic, road and weather conditions vary. Other motorists' actions are unpredictable. Your motorcycle's condition can change. These factors can best be dealt with by giving every ride your full attention.

Circumstances beyond your control could lead to an accident. You need to prepare for the unexpected by wearing a helmet and other protective gear, and learning emergency braking and swerving techniques to minimize the damage to you and your machine.

The best way to learn basic riding skills and evasive maneuvers or refresh your own riding skills is to take one of the courses offered by the Motorcycle Safety Foundation. Your Suzuki dealer can help you locate the fundamental or advanced riding skills course nearest you, or owners in the USA can call toll-free 1-800-446-9227.

Good riding on your new Suzuki!

FUEL, ENGINE OIL AND COOLANT RECOMMENDATIONS

FUEL 2-2
ENGINE OIL 2-4
ENGINE COOLANT SOLUTION 2-6

PartShark.com
877-999-5686

FUEL, ENGINE OIL AND COOLANT RECOMMENDATIONS

FUEL

Your motorcycle requires premium unleaded gasoline with a minimum pump octane rating of 90 ((R+M)/2 method). In some areas, the only fuels that are available are oxygenated fuels.

NOTE: The GSX-R1000 engine is designed to use premium unleaded gasoline only. Use premium unleaded gasoline under all riding conditions.

Oxygenated fuels which meet the minimum octane requirement and the requirements described below may be used in your motorcycle without jeopardizing the New Vehicle Limited Warranty or the Emission Control System Warranty.

NOTE: Oxygenated fuels are fuels which contain oxygen-carrying additives such as MTBE or alcohol.

Gasoline Containing MTBE

Unleaded gasoline containing MTBE (Methyl Tertiary Butyl Ether) may be used in your motorcycle if the MTBE content is not greater than 15%. This oxygenated fuel does not contain alcohol.

Gasoline/Ethanol Blends

Blends of unleaded gasoline and ethanol (grain alcohol), also known as "GASOHOL", may be used in your motorcycle if the ethanol content is not greater than 10%.

Gasoline/Methanol Blends

Fuels containing 5% or less methanol (wood alcohol) may be suitable for use in your motorcycle if they contain co-solvents and corrosion inhibitors.

DO NOT USE fuels containing more than 5% methanol under any circumstances. Fuel system damage or motorcycle performance problems resulting from the use of such fuels are not the responsibility of Suzuki and may not be covered under the New Vehicle Limited Warranty or the Emission Control System Warranty.

Fuel Pump Labeling

In some states, pumps that dispense oxygenated fuels are required to be labeled for the type and percentage of oxygenate, and whether important additives are present. Such labels may provide enough information for you to determine if a particular blend of fuel meets the requirements listed above. In other states, pumps may not be clearly labeled as to the content or type of oxygenate and additives. If you are not sure that the fuel you intend to use meets these requirements, check with the service station operator or the fuel supplier.

NOTE:

- *To help minimize air pollution, Suzuki recommends that you use oxygenated fuels.*
- *Be sure that any oxygenated fuel you use has octane ratings of at least 90 pump octane ((R+M)/2 method).*
- *If you are not satisfied with the driveability of your motorcycle when you are using an oxygenated fuel, or if engine ping-ing is experienced, substitute another brand as there are differences between brands.*

CAUTION

Spilled gasoline containing alcohol can harm your motorcycle. Alcohol can damage painted surfaces.

Be careful not to spill any fuel when filling the fuel tank. Wipe spilled gasoline up immediately.

ENGINE OIL

Oil quality is a major contributor to your engine's performance and life. Always select good quality engine oil. Suzuki recommends the use of SUZUKI PERFORMANCE 4 MOTOR OIL or equivalent engine oil. Use oil with an API (American Petroleum Institute) classification of SF/SG or SH/SJ, or with a JASO classification of MA.

SAE	API	JASO
10W-40	SF or SG	-
10W-40	SH or SJ	MA

API: American Petroleum Institute
JASO: Japanese Automobile Standards Organization

SAE Engine Oil Viscosity

Suzuki recommends the use of SAE 10W-40 engine oil. If SAE 10W-40 engine oil is not available, select an alternative according to the following chart.

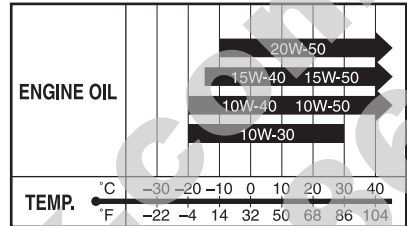

JASO T903

The JASO T903 standard is an index to select engine oils for 4-stroke motorcycle and ATV engines. Motorcycle and ATV engines lubricate clutch and transmission gears with engine oil. JASO T903 specifies performance requirements for motorcycle and ATV clutches and transmissions.

There are two classes, MA and MB. The oil container shows the classification as follows.

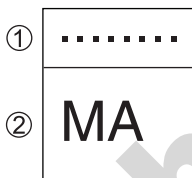

- ① Code number of oil sales company
- ② Oil classification

Energy Conserving

Suzuki does not recommend the use of “ENERGY CONSERVING” oils. Some engine oils which have an API classification of SH or higher have an “ENERGY CONSERVING” indication in the API classification doughnut mark. These oils can affect engine life and clutch performance.



Not recommended



Recommended

ENGINE COOLANT SOLUTION

Use engine coolant that is compatible with an aluminum radiator, mixed with distilled water at a 50:50 mixture ratio for engine coolant solution. An engine coolant mixture other than 50:50 can affect cooling efficiency or rust inhibiting performance.

Engine Coolant

Engine coolant should be used at all times in your motorcycle's radiator, even if the temperature in your area does not go down to the freezing point. Engine coolant acts as a rust inhibitor and water pump lubricant as well as an anti-freeze solution.

WARNING

Engine coolant is harmful or fatal if swallowed or inhaled.

Do not drink antifreeze or coolant solution. If swallowed, do not induce vomiting. Immediately contact a poison control center or a physician. Avoid inhaling mist or hot vapors; if inhaled, remove to fresh air. If coolant gets in eyes, flush eyes with water and seek medical attention. Wash thoroughly after handling. Solution can be poisonous to animals. Keep out of the reach of children and animals.

CAUTION

Spilled engine coolant can damage painted surfaces.

Do not spill any fluid when filling the radiator. Wipe spilled engine coolant up immediately

Water for Mixing

Use distilled water only. Water other than distilled water can corrode and clog the aluminum radiator.

Required amount of engine coolant/water solution capacity (total): 2800 ml (3.0 US qt)

Engine coolant	1400 ml (1.5 US qt)
Water	1400 ml (1.5 US qt)

CONTROLS, EQUIPMENT AND ADJUSTMENTS

LOCATION OF PARTS	3-2
KEY	3-5
IGNITION SWITCH	3-5
INSTRUMENT PANEL	3-8
LEFT HANDLEBAR	3-22
RIGHT HANDLEBAR	3-25
FUEL TANK CAP	3-27
GEARSHIFT LEVER	3-28
REAR BRAKE PEDAL	3-28
SEAT LOCK AND HELMET HOLDERS	3-29
SIDE STAND	3-31
SUSPENSION ADJUSTMENT	3-32
FOOTRESTS AND GEARSHIFT LEVER POSITION CHANGE	3-36

CONTROLS, EQUIPMENT AND ADJUSTMENTS

LOCATION OF PARTS

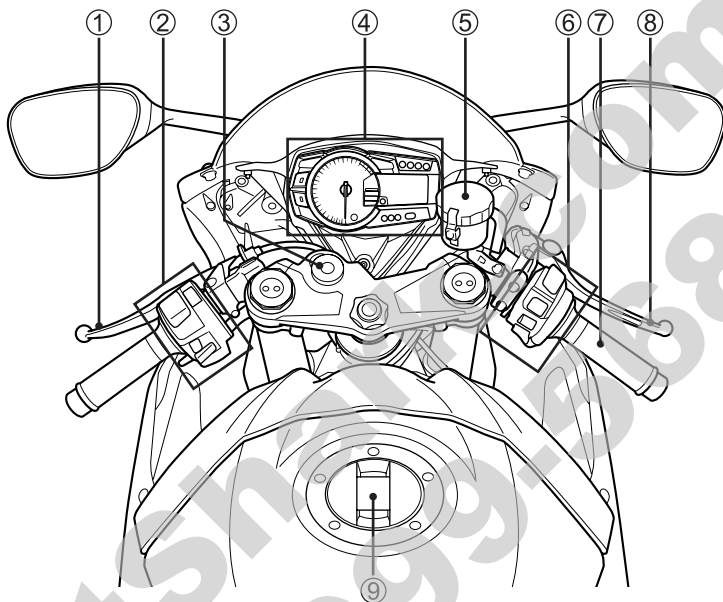

- ① Clutch lever
- ② Left handlebar switches
- ③ Ignition switch
- ④ Instrument panel
- ⑤ Front brake fluid reservoir
- ⑥ Right handlebar switches
- ⑦ Throttle grip
- ⑧ Front brake lever
- ⑨ Fuel tank cap

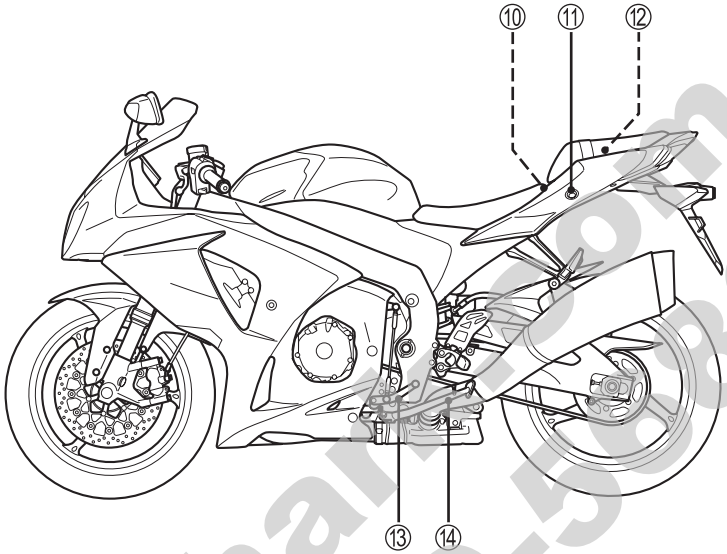

- ⑩ Tools
- ⑪ Seat lock
- ⑫ Helmet holders
- ⑬ Gearshift lever
- ⑭ Side stand

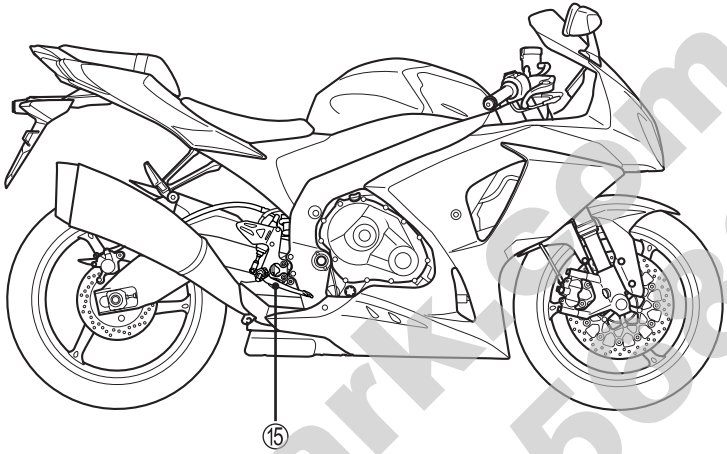

⑮ Rear brake pedal

KEY

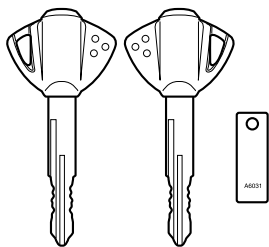

Two keys come with this motorcycle. Keep the spare key in a safe place. An identifying number is stamped on the plate. Use this number when making a replacement key.

Please write down your key number in the box provided for your future reference.

Key number:

⚠ WARNING

Due to the location of the steering damper, some key chains could get caught between the steering damper and the steering stem nut. This could interfere with steering and cause loss of control.

Use your ignition key without key chains, fobs or other keys attached.

IGNITION SWITCH

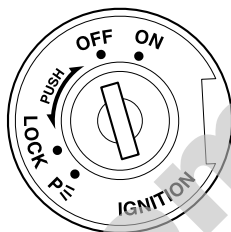

The ignition switch has 4 positions:

“OFF” position

All electrical circuits are cut off. The engine will not start. The key can be removed.

“ON” position

The ignition circuit is completed and the engine can run. The headlight and taillight will automatically turn on. The key cannot be removed in this position.

NOTE: Start the engine promptly after turning the key to the “ON” position, or the battery will lose power due to consumption by the headlight and taillight.

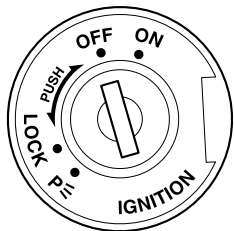

“LOCK” position

All electrical circuits are off. The key can be removed and the steering will be locked. Turn the steering all the way to the left and push down the key and turn it to the “LOCK” position.

“P” (PARKING) position

Taillight will come on to increase visibility for temporary road side parking at night. The key can be removed and the steering will be locked.

WARNING

Turning the ignition switch to the “P” (PARKING) or “LOCK” position while the motorcycle is moving can be hazardous. Moving the motorcycle while the steering is locked can be hazardous. You could lose your balance and fall, or you could drop the motorcycle.

Stop the motorcycle and place it on the side stand before locking the steering. Never attempt to move the motorcycle when the steering is locked.

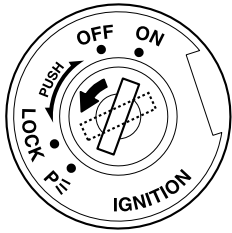

The key hole can be covered by turning the lid.

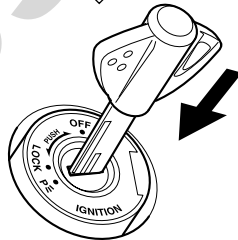
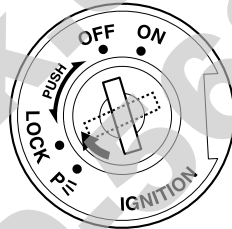
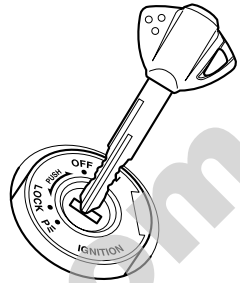

Align the lid hole position with the key hole position when inserting the key.

INSTRUMENT PANEL

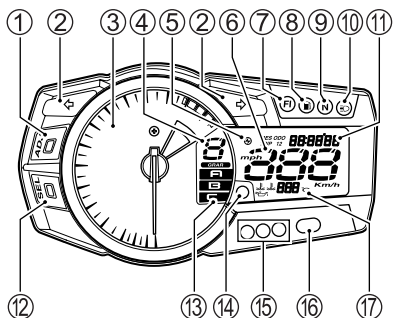

The electronic control system indicator light ⑦, fuel indicator light ⑧, coolant temperature indicator/oil pressure indicator light ⑭, engine rpm indicator lights ⑮, ⑯, LCD's and tachometer needle work as follows to confirm their function when the ignition switch is turned to the "ON" position.

- The electronic control system indicator light ⑦, fuel indicator light ⑧, coolant temperature indicator/oil pressure indicator light ⑭ and engine rpm indicator lights ⑮, ⑯ come on for 3 seconds.
- The tachometer needle moves to the full scale position and returns to the home position.
- All LCD segments will have appear/disappear action and then show normal display.

If the tachometer needle does not point to zero, follow the procedure below to reset the tachometer.

1. Press and hold the ADJ button ① and turn on the ignition switch.
2. Hold the ADJ button ① for 3 – 5 seconds.
3. Release the ADJ button ①. Rap the ADJ button twice.

NOTE: Reset procedure, from step 1 to step 3, should be performed within 10 seconds.

Turn Signal Indicator Light

"↔" ②

When either the right or left turn signals are being operated, the indicator light will flash intermittently.

NOTE: If a turn signal light is not operating properly due to bulb filament or circuit failure, the indicator light flickers more quickly to notify the rider of the existence of the failure.

Tachometer ③

The tachometer indicates the engine speed in revolutions per minute (r/min).

Gear Position Indicator ④

The gear position indicator indicates gear position. This indicator displays “0” when the transmission is in neutral.

NOTE: When the display indicates “CHEC”, the gear position indicator does not indicate a number but indicates “-”.

Speedometer ⑥

The speedometer indicates the road speed in kilometers per hour and miles per hour.

NOTE:

- *Set the meter to odometer, then press and hold buttons, ADJ ① and SEL ⑫, for 3 seconds to switch between km/h and mph.*
- *Select km/h or, mph as appropriate, to comply with traffic regulations.*
- *Check km/h and mph display after adjusting the instrument panel display.*

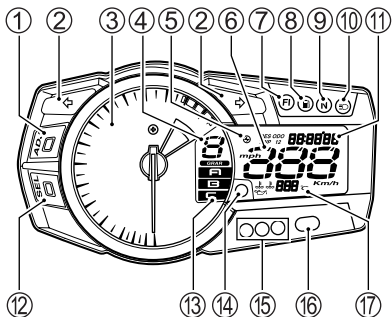

Electronic Control Indicator ⑦

FI
Sd

If the electronic control system fails, the red indicator light ⑦ comes on and the display indicates “FI” or “Sd” in the odometer display area in following 2 modes;

A. The display ⑪ indicates “FI” or “Sd” and the displayed mode alternately, and the red indicator light ⑦ comes on and remains lit. The engine may continue to run in this mode. The display ⑪ indicates “FI”, “Sd” and the displayed mode repeatedly when both fuel injection system and steering damper system failed.

B. The display ⑪ indicates “FI” continuously and the red indicator light ⑦ blinks. The engine will not run in this mode.

NOTE: The indicator displays “FI” when the fuel injection system has malfunction. The indicator displays “Sd” when the steering damper solenoid, battery voltage and speed sensor have malfunction.

CAUTION

Riding the motorcycle with the display indicating a problem with the electronic control system can damage the engine.

Whenever the red indicator light is lit and the display indicates “FI” or “Sd”, have your authorized Suzuki dealer or a qualified mechanic inspect the electronic control system as soon as possible.

NOTE:

- If the display indicates “FI” or “Sd” and the displayed mode alternately, and the red indicator light comes on and remains lit, keep the engine running and bring your motorcycle to an authorized Suzuki dealer. If the engine stalls, try restarting the engine after turning the ignition switch off and on.
- If the display indicates “FI” continuously and the red indicator light blinks, the engine will not start.

CHEC

When the display indicates “CHEC” in the odometer display area check following items;

- Make sure that the engine stop switch is in the “O” position.
- Make sure that the transmission is in neutral or the side stand is fully up.

If the display still indicates “CHEC” after checking the above items, inspect the ignition fuse and the connection of the lead wire couplers.

Fuel Indicator Light “” ⑧

This indicator light comes on for 3 seconds when the ignition switch is turned to the “ON” position. Then the indicator light should go out if there is enough fuel in the tank. When the fuel in the fuel tank drops below approximately 4.0 L (1.1 US gal), this indicator blinks. When the fuel in the fuel tank drops below approximately 1.5 L (0.4 US gal), this indicator light comes on and remains on.

NOTE: When the fuel indicator light comes on, you should add fuel to the fuel tank at the first opportunity to avoid running out of fuel.

Neutral Indicator Light “N” ⑨

The green indicator light will come on when the transmission is in neutral. The light will go out when you shift into any gear other than neutral.

High Beam Indicator Light “”

⑩

This blue indicator light will be lit when the headlight high beam is turned on.

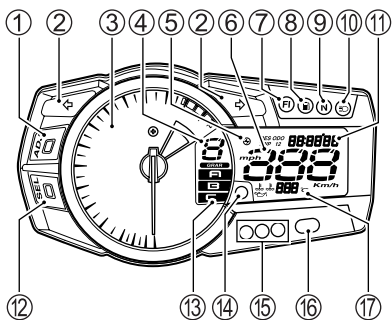

**Odometer/Trip Meter/
Reserve Trip Meter/Clock/
Instrument Panel Light
Brightness/
Lap Time Counter ⑪**

The display has 7 functions; odometer, 2 trip meters, reserve trip meter, clock, instrument panel light brightness and lap time counter. When the ignition switch is turned to the "ON" position, the test pattern is displayed. The display is memorized when the ignition switch is turned off and the memorized display appears when the ignition switch is turned on again.

To change the display, push the SEL button ⑫ or right handlebar switch of lap time counter switch. The display changes in the order below.

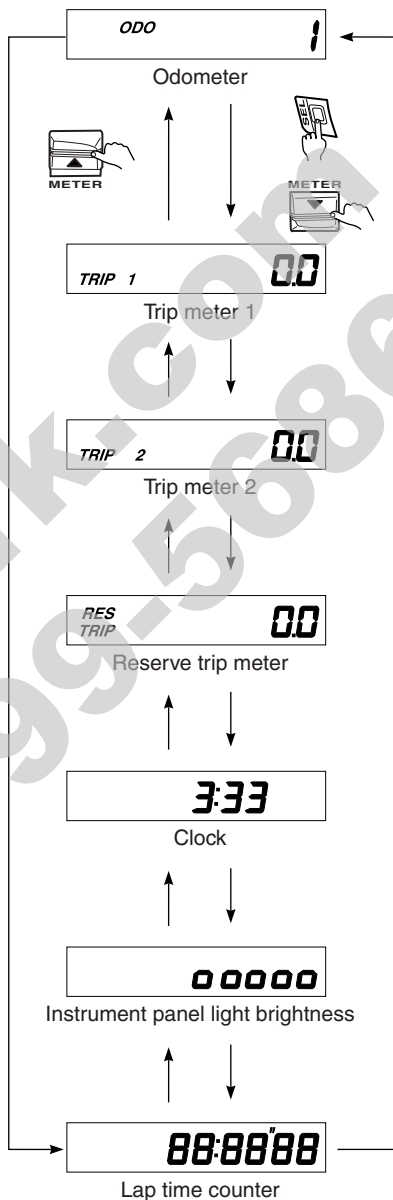

Odometer

The odometer registers the total distance that the motorcycle has been ridden.

Trip meter

The 2 trip meters are resettable odometers. They can register 2 kinds of distances at the same time. For instance, trip meter 1 can register the trip distance and trip meter 2 can register the distance between fuel stops.

To reset a trip meter to zero, push the ADJ button ① or METER ▲ or METER ▼ for 2 seconds while the display indicates the trip meter, 1 or 2, you want to reset.

Reserve trip meter

The reserve trip meter counts distance from fuel tank reserve point until the fuel tank is refilled. The fuel level indicator starts blinking and the reserve trip meter starts counting when the fuel level reaches the reserve point. The trip meter will be reset to zero automatically when the fuel tank is refilled over halfway and the motorcycle starts moving. The reserve trip meter can be reset manually by pushing the ADJ button ① or METER ▲ or METER ▼ for more than 5 seconds with fuel tank filled over halfway.

WARNING

Operating the display while riding can be hazardous. Removing a hand from the handlebars can reduce your ability to control the motorcycle.

Always keep both hands on the handlebars during riding.

Clock

The clock has a 12-hour display. Follow the procedure below to adjust the clock.

1. Press and hold the SEL button ⑫ for 3 seconds until the hour display blinks.
2. Adjust the hour display by pushing the ADJ button ①.

NOTE: When the ADJ button ① is held in, the display advances continuously.

3. Push the SEL button ⑫ or METER ▲ or METER ▼ to highlight the minute display.
4. Adjust the minute display by pushing the ADJ button ①.
5. Push the SEL button ⑫ or METER ▲ or METER ▼ to return to the clock mode.

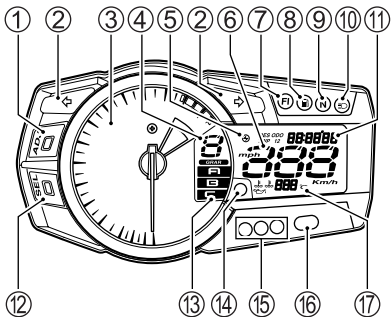

Instrument panel light brightness

Pushing the ADJ button ① will change the instrument panel light brightness in 5 steps. The brightness indicator indicates brightness from “0” (min) to “00000” (max).

Lap time counter

The lap time counter can counts 99 lap times and total time. The lap time counter indicates from 00:00”00 to 99:59”99.

1. To use lap time counter



Push SEL button ⑫, METER ▲ or METER ▼ to select lap time counter. The display blinks 00:00”00 or memory data when the lap time counter is selected. The lap time counter cannot be operated when the display is blinking.

2. To measure lap time

00:00'00

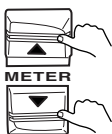

1. Press and hold the SEL button ②, METER ▲ or METER ▼ for more than 1 second. The display stops blinking.

00:00'00



00:00'01



2. Push METER ▼ to start lap time counter.

① L01



② 02:31'53



③ 23:18'15



- ① Lap number
- ② Lap time
- ③ Total time

3. When the METER ▲ is pushed, the lap time counter records lap time data and the display shows lap number and then shows lap time for 4 seconds.

57:39'27



4. Push METER ▼ to stop lap time counter.

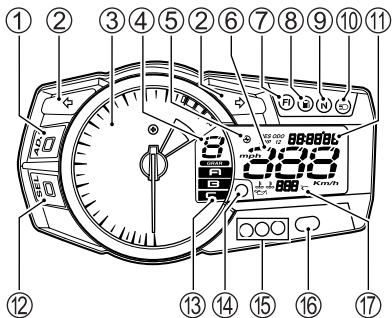

3. To check lap time memory data

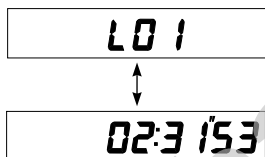

1. Press and hold the SEL button ⑫ for more than 3 seconds. Display shows lap number and lap time alternately.

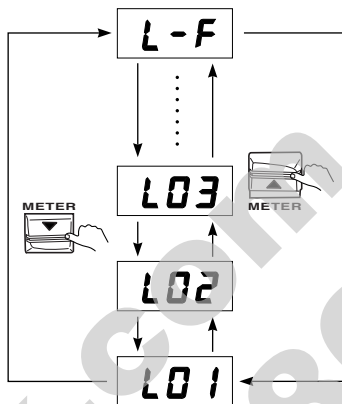

2. Push METER ▲ or METER ▼ to increase or decrease lap number.

3. L - F indicates minimum lap time.

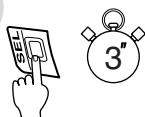
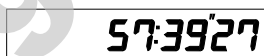

4. Press and hold the SEL button ⑫ for more than 3 seconds. The lap time counter returns to lap time measure mode.

4. To clear lap time memory data

57:39'27



00:00'00

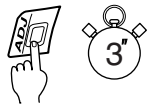

1. Press and hold ADJ button ① for more than 3 seconds to clear the lap time memory data.
2. The lap time counter shows 00:00'00.

Suzuki Drive Mode Indicator ⑬



The Suzuki drive mode indicator displays drive mode, A, B and C, when the Suzuki drive mode selector is activated. Refer to the LEFT HANDLEBAR section for detail.

Coolant Temperature Indicator/ Oil Pressure Indicator ⑭

The display ⑰ and the indicator light ⑭ have 2 functions, coolant temperature indicator and oil pressure indicator. The display ⑰ normally indicates coolant temperature. The oil pressure symbol “” activates when the oil pressure is low.

Coolant Temperature Indicator

When the ignition switch is turned to the “ON” position, the display shows the test pattern for 3 seconds. Then the display changes to the coolant temperature indicator. While the coolant temperature is below 19°C (67°F), the display does not indicate a number but indicates “-- --”.

When the coolant temperature is higher than 120°C (248°F), the display temperature, symbol “” flickers and the indicator light ⑭ comes on. Further, if the temperature exceeds 140°C (283°F), the display shows “HI”, symbol “” flickers and the indicator light ⑭ remains on.

CAUTION

Running the engine with high engine coolant temperature can cause serious engine damage. If the engine coolant temperature indicates greater than 120°C (248°F) and the indicator light comes on, stop the engine to let it cool.

Do not run the engine until the coolant temperature indicates 120°C (248°F) or below.

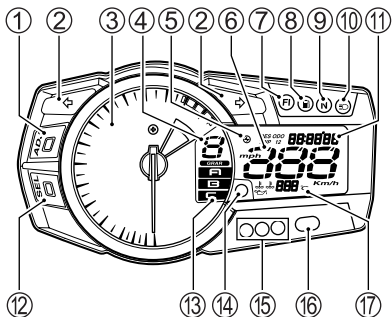

Oil Pressure Indicator

With the ignition switch in the "ON" position but the engine is not started, the symbol "🛢️" in the display and the indicator light ⑭ comes on. As soon as the engine is started, the symbol "🛢️" and the indicator light should go out.

When the engine oil pressure drops under the normal operating range, the symbol "🛢️" in the display appears and the indicator light ⑭ comes on.

CAUTION

Riding the motorcycle when the symbol "🛢️" appears and the indicator light is lit can damage the engine and transmission.

Whenever the symbol "🛢️" appears and the indicator lights up, indicating low oil pressure, stop the engine immediately. Check the oil level and make sure the proper amount of oil is in the engine. If the light still does not go out, have your authorized Suzuki dealer or a qualified mechanic troubleshoot your motorcycle.

Engine Rpm Indicator ¹⁵, ¹⁶

The engine rpm indicator LED's will light or blink when the engine speed reaches a preset engine rpm.

NOTE: Be sure to reset the engine rpm indicator in the instrument panel when the battery terminals are reconnected.

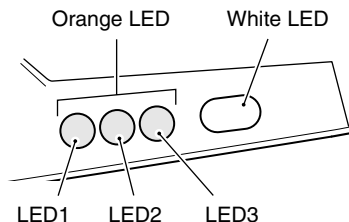

When the white LED is set at 10000 r/min and orange LED range is set at 500 r/min.

Engine rpm and preset rpm (r/min)	Orange LED ¹⁵			White LED ¹⁶	
	LED1	LED2	LED3		
Engine rpm < 8500	–	–	–	–	
8500 ≤ Engine rpm < 9000	○	–	–	–	
9000 ≤ Engine rpm < 9500	○	○	–	–	
9500 ≤ Engine rpm < 10000	○	○	○	–	
10000 ≤ Engine rpm	○	○	○	○	* Blink

The LED setting will be changed as follows:

1. White LED Lighting → 2. White LED Brightness → 3. White LED Pre-set RPM Setting → 4. Orange LED Preset RPM Range Setting

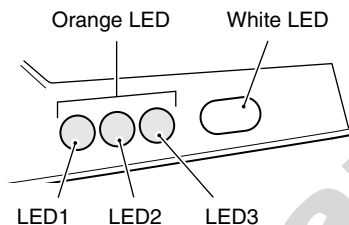
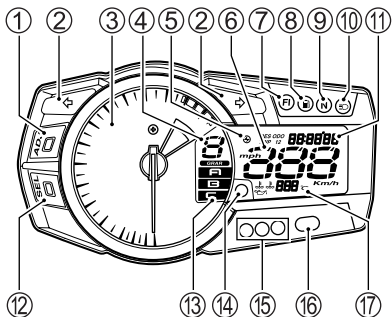

1. White LED Lighting

	LIGHT	BLINK	NO LIGHT
White LED	○	⚡ Blink	—
Indicator mark ⚡	⚡	⚡	—

1. Press and hold the SEL button ⑫ and turn on the ignition switch. Keep the SEL button ⑫ pressed for more than 2 seconds.
2. Push the ADJ button ① to change the lighting mode. The mode changes as follows: LIGHT → BLINK → NO LIGHT → LIGHT. The white LED comes on in the LIGHT mode and blinks in the BLINK mode. The engine rpm indicator mark “⚡” comes on when the mode is in LIGHT or BLINK mode is selected. When the SEL button ⑫ is pushed in the NO LIGHT mode, the selection mode will be canceled and it will return the normal display mode.

2. White LED Brightness

1. Push the SEL button ⑫ from white LED lighting mode to change white LED brightness mode.
2. Push the ADJ button ① to change brightness in 5 steps. The brightness indicator changes from “0” (min) to “00000” (max).

3. White LED Preset RPM Setting

1. Push the SEL button ⑫ from the white LED brightness mode to change white LED preset rpm setting. The white LED will light preset setting and tachometer indicates preset rpm.
2. Push the ADJ button ① to change the preset rpm from 5000 r/min to 10000 r/min in step 250 r/min and from 10000 r/min to 13750 r/min in step 50 r/min. When the ADJ button ① is held in, the preset rpm will advance continuously.

4. Orange LED Preset RPM Range Setting

1. Push the SEL button ⑫ from the white LED preset rpm setting mode to change orange LED preset rpm range setting.
2. Push the ADJ button ① to change orange LED preset rpm range as follows: 250 r/min → 500 r/min → 1000 r/min → 250 r/min

When the White LED is preset at 10000 r/min.

Orange LED preset rpm range ⑪	Orange LED ⑮			White LED ⑯
	LED1	LED2	LED3	
250	9250	9500	9750	10000
500	8500	9000	9500	10000
1000	7000	8000	9000	10000

3. Push the SEL button ⑫ to return from adjustment mode to normal display mode.

The engine rpm indicator system holds the selected setting when the ignition switch is turned off. The system settings will remain when the ignition switch is turned on again.

LEFT HANDLEBAR

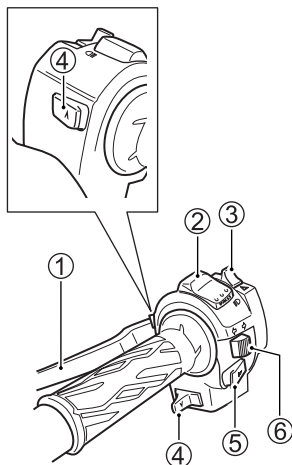

Clutch Lever ①

The clutch lever is used for disengaging the drive to the rear wheel when starting the engine or shifting transmission gears. Squeezing the lever disengages the clutch.

Dimmer Switch ②

“” position

The headlight low beam and taillight turn on.

“” position

The headlight high beam, headlight low beam and taillight turn on. The high beam indicator light also turns on.

Headlight flasher switch

Press the dimmer switch of “” position to flash the headlight high beam.

CAUTION

Sticking some tape or placing objects in front of the headlight can damage the headlight.

Do not stick any tapes to the headlight. Do not place objects in front of the headlight.

Hazard Warning Switch “” ③

All four turn signal lights and indicators will flash simultaneously when the switch is turned on with the ignition switch in the “ON” or “P” position. Use the hazard warning lights to warn other traffic during emergency parking or when your vehicle could otherwise become a traffic hazard.

Suzuki Drive Mode Selector ④

Engine power characteristics can be changed in 3 modes by operating the Suzuki drive mode selector to meet various riding conditions and rider's preference.

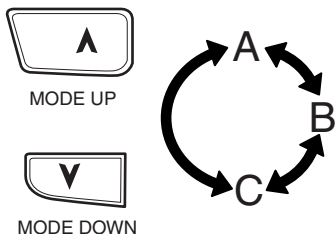

Suzuki drive mode selector operation

Drive mode is preset at A-mode when the ignition switch and the engine stop switch are turned on. At this time, the Suzuki drive mode indicator shows nothing. Follow the procedure below to operate the Suzuki drive mode selector.

1. Turn on the ignition switch and the engine stop switch.
2. Push the Suzuki drive mode selector UP "▲" or DOWN "▼" for 1 second until the Suzuki drive mode indicator shows A.
3. Push the Suzuki drive mode selector to change drive mode. Pushing the UP "▲" switch can change from A to C to B to A. Pushing the DOWN "▼" switch can change from A to B to C to A. The Suzuki drive mode indicator indicates actual drive mode.

NOTE:

- Operating the Suzuki drive mode selector while riding with the throttle opened will change the engine speed because of engine power characteristics change.
- The Suzuki drive mode indicator blinks when drive mode change operation is failed.
- Turning off the ignition switch or the engine stop switch will return the drive mode to A-mode. Start the engine and reset the drive mode.

Drive mode

Engine power

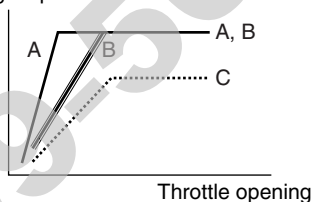

A-mode

A-mode provides sharp throttle response at all throttle opening range to obtain maximum engine power.

B-mode

B-mode provides softer throttle response than A-mode up to middle throttle opening range.

C-mode

C-mode provides soft throttle response at all throttle opening range by reducing engine power.

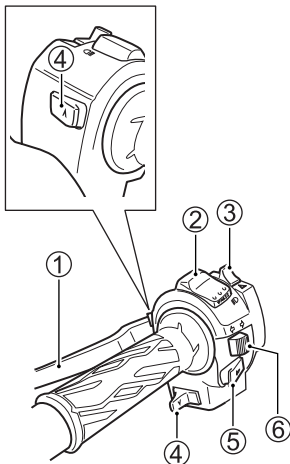



Horn Switch “” ⑤

Press the switch to sound the horn.

Turn Signal Light Switch

“” ⑥

Moving the switch to the “” position will flash the left turn signals. Moving the switch to the “” position will flash the right turn signals. The indicator light will also flash intermittently. To cancel turn signal operation, push the switch in.

WARNING

Failure to use the turn signals, and failure to turn off the turn signals can be hazardous. Other drivers may misjudge your course and this may result in an accident.

Always use the turn signals when you intend to change lanes or make a turn. Be sure to turn off the turn signals after completing the turn or lane change.

RIGHT HANDLEBAR

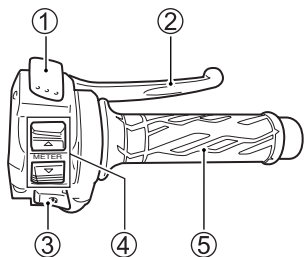

Engine Stop Switch ① “~~X~~” position

The ignition circuit is off. The engine cannot start or run.

“Q” position

The ignition circuit is on and the engine can run.

Front Brake Lever ②

Apply the front brake by squeezing the front brake lever towards the grip. The brake light will come on when the lever is squeezed.

Front Brake Lever Adjustment

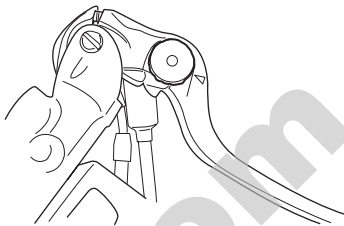

The distance between the throttle grip and the front brake lever is adjustable to 6 positions. To change the position, push the brake lever forward and turn the adjuster to the desired position. When changing the brake lever position, always be sure the adjuster stops in the proper position; a projection of the brake lever holder should fit into the depression of the adjuster. This motorcycle is delivered from the factory with its adjuster set on position 3.

⚠ WARNING

Adjusting the front brake lever position while riding can be hazardous. Removing a hand from the handlebars can reduce your ability to control the motorcycle.

Always keep both hands on the handlebars while riding.

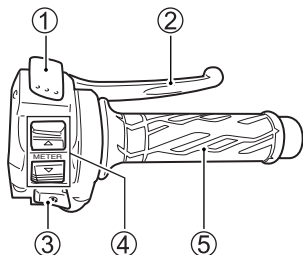

CAUTION

To prevent electrical system damage, do not operate the starter motor longer than 5 seconds at a time.

If the engine does not start after several attempts, check the fuel supply and ignition system. Refer to the TROUBLESHOOTING section in this manual.

Electric Starter Button “” ③

Use this button to operate the starter motor. With the ignition switch in the “ON” position, the engine stop switch in the “” position, and the transmission is in neutral, pull in the clutch lever and push the electric starter button to start the engine.

NOTE: This motorcycle has a starter interlock system for the ignition and starter circuit. The engine can only be started if:

- The transmission is in neutral and the clutch is disengaged, or
- The transmission is in gear, the side stand is fully up and the clutch is disengaged.

NOTE: The headlight will go off when the electric starter button is pushed.

Lap Time Counter Switch ④

To change the display, push the lap time counter switch. Refer to the INSTRUMENT PANEL section for detail.

Throttle Grip ⑤

Engine speed is controlled by the position of the throttle grip. Twist it toward you to increase engine speed. Turn it away from you to decrease engine speed.

FUEL TANK CAP

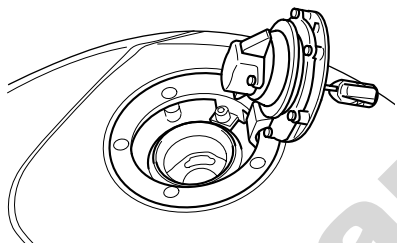
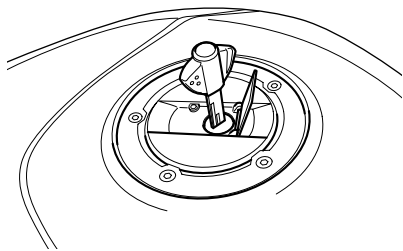

To open the fuel tank cap, insert the ignition key into the lock and turn it clockwise. With the key inserted, lift up with the key and open the fuel tank cap. To close the fuel tank cap, push the cap down firmly with the key in the cap lock.

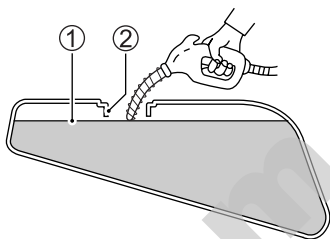

- ① Fuel level
- ② Filler neck

⚠ WARNING

Overfilling the fuel tank can cause the fuel to overflow when it expands due to heat from the engine or the sun. Spilled fuel can catch on fire.

Never fill the fuel above the bottom of the filler neck.

⚠ WARNING

Fuel and fuel vapor are highly flammable and toxic. You can be burned or poisoned when refueling.

- Stop the engine and keep flames, sparks and heat sources away.
- Refuel only outdoors or in a well ventilated area.
- Do not smoke.
- Wipe up spills immediately.
- Avoid breathing fuel vapor.
- Keep children and pets away.

GEARSHIFT LEVER

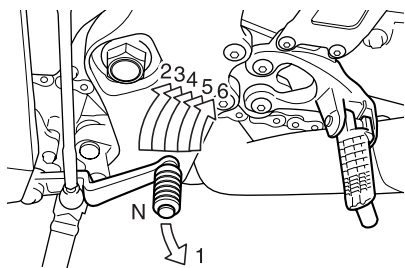

This motorcycle has a 6-speed transmission which operates as shown. To shift properly, squeeze the clutch lever and close the throttle at the same time you operate the gearshift lever. Lift the gearshift lever to upshift and depress the lever to downshift. Neutral is located between 1st and 2nd gear. When neutral is desired, depress or lift the lever halfway between 1st and 2nd gear.

NOTE: When the transmission is in neutral, the green indicator light on the instrument panel will be lit. However, even though the light is illuminated, cautiously and slowly release the clutch lever to make sure that the transmission is positively in neutral.

REAR BRAKE PEDAL

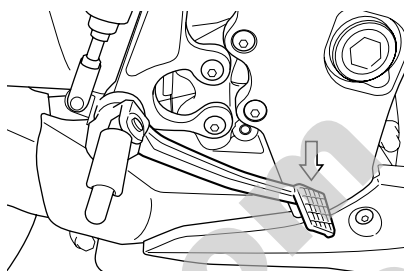

Depressing the rear brake pedal will apply the rear disk brake. The brake light will be illuminated when the rear brake is operated.

SEAT LOCK AND HELMET HOLDERS

Front Seat

To remove the front seat.

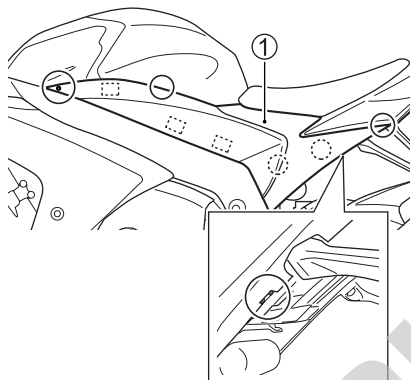

1. Remove the bolts and fasteners. Unhook the hooks. Remove the right and left side frame cover ①.

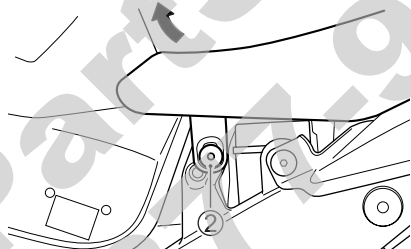

2. Remove the right and left bolts ②.
3. Raise the front end of the seat and slide it forward.

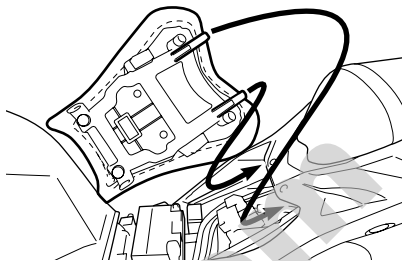

To reinstall the seat, slide the seat hooks into the seat hook retainers on the frame and tighten the bolts securely.

▲ WARNING

Failure to install the seat properly could allow the seat to move and cause loss of rider control.

Fasten the seat securely in its proper position.

Rear Seat

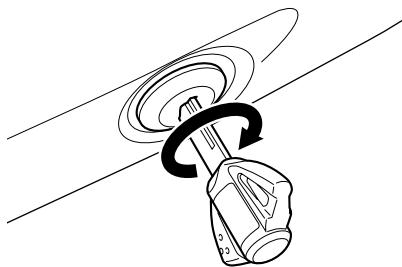

The seat lock is located under the left frame cover. To remove the rear seat, insert the ignition key into the lock and turn it clockwise.

Raise the front end of the seat and slide it forward.

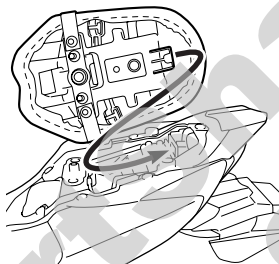

To reinstall the seat, slide the seat hooks into the seat hook retainers and push down firmly until the seat snaps into the locked position.

WARNING

Failure to install the seat properly could allow the seat to move and cause loss of rider control.

Latch the seat securely in its proper position.

A seat tail cover for solo riding can be attached by using the same procedure as for installing the rear seat.

Helmet Holders

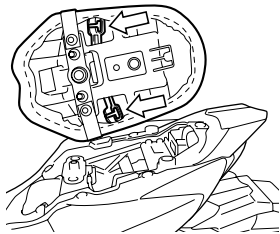

This motorcycle has helmet holders underneath the rear seat. Hook your helmet on the helmet holder and lock the seat.

▲ WARNING

Riding with a helmet fastened to the helmet holder can interfere with rider control.

Never carry a helmet fastened to the helmet holder. Fix the helmet securely atop the seat if you must carry it.

SIDE STAND

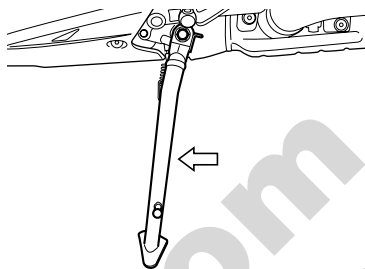

An interlock switch is provided to cut off the ignition circuit when the side stand is down and the transmission is in any gear other than neutral.

The side stand/ignition interlock switch works as follows:

- If the side stand is down and the transmission is in gear, the engine can not be started.
- If the engine is running and the transmission is shifted into gear with the side stand down, the engine will stop running.
- If the engine is running and the side stand is put down with the transmission in gear, the engine will stop running.

⚠ WARNING

Riding with the side stand incompletely retracted can result in an accident when you turn left.

- Check operation of the side stand/ignition interlock system before riding.
- Always retract the side stand completely before starting off.

CAUTION

Park the motorcycle on firm, level ground to help prevent it from falling over.

If you must park on an incline, aim the front of the motorcycle uphill and put the transmission into 1st gear to reduce the possibility of rolling off the side stand.

SUSPENSION ADJUSTMENT

The standard settings for both the front and rear suspensions are selected to meet various riding conditions such as low to high motorcycle speed and light to heavy load on the motorcycle. The suspension settings can be adjusted to fine-tune then according your preference.

FRONT SUSPENSION Spring Pre-load Adjustment

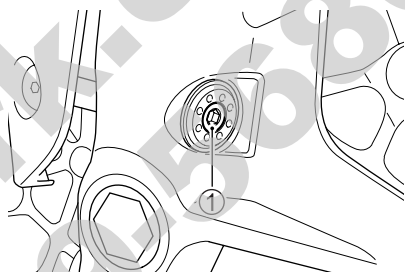

To set the spring pre-load adjuster to the standard position, turn the adjuster ① counterclockwise until it stops and turn the adjuster clockwise 4 turns. Turn the adjuster clockwise from the standard position to stiffen the spring pre-load. Turn the adjuster counterclockwise to soften the spring pre-load. The spring pre-load should be adjusted gradually to fine-tune the suspension. Adjust the right and left front forks to the same setting.

Damping Force Adjustment

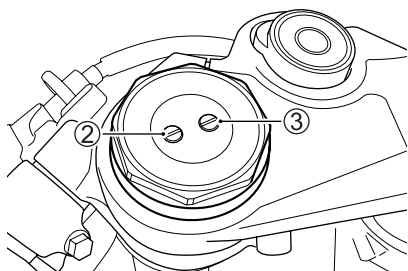

The rebound and compression damping force can be individually adjusted by turning the respective adjusters. The rebound damping force adjuster ② and compression damping force adjuster ③ are located at the top of the front suspension.

To adjust the damping force, set the adjuster to the standard setting first and then adjust the adjuster to the desired position.

To set the rebound damping force adjuster to the standard position, turn the adjuster clockwise until it stops and then turn it counterclockwise 4 turns.

Turn the adjuster clockwise from the standard position to stiffen the damping force. Turn the adjuster counterclockwise to soften the damping force. The damping force should be adjusted gradually, 1/8 turn at a time, to fine-tune the suspension.

To set the compression damping force adjuster to the standard position, turn the adjuster clockwise until it stops and then turn it counterclockwise 5 turns.

Turn the adjuster clockwise from the standard position to stiffen the damping force. Turn the adjuster counterclockwise to soften the damping force. The damping force should be adjusted gradually, 1/8 turn at a time, to fine-tune the suspension.

▲ WARNING

Unequal suspension adjustment can cause poor handling and loss of stability.

Adjust the right and left front forks to the same settings.

REAR SUSPENSION

Spring Pre-load Adjustment

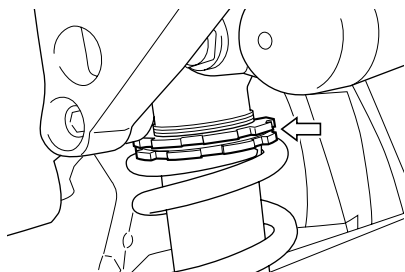

This adjustment can be performed by changing the adjuster ring position. However, Suzuki recommends that this adjustment be done by your authorized Suzuki dealer, since a special tool is needed for this job.

Damping Force Adjustment

Three damping forces, rebound, high stroke speed compression and low stroke speed compression, can be individually adjusted by turning the respective adjusters. The rebound damping force adjuster ① is located at the bottom of the rear suspension. The high stroke speed and low stroke speed compression damping force adjusters ②, ③ are located at the left side of the rear suspension.

To adjust the damping force, set the adjuster to the standard setting first and then adjust the adjuster to the desired position.

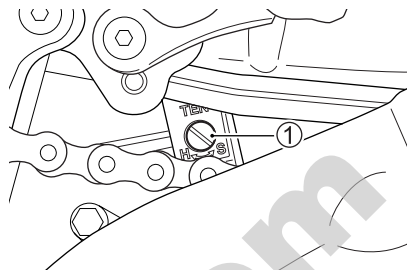

To set the rebound damping force adjuster to the standard position, turn the adjuster clockwise until it stops and then turn it counter-clockwise 2 and 3/4 turns until the two punch marks align. If the two punch marks do not align by turning out 2 and 3/4 turns, turn in or out the adjuster until two punch marks align.

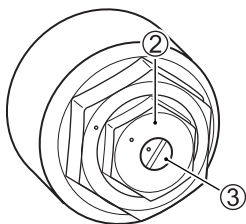
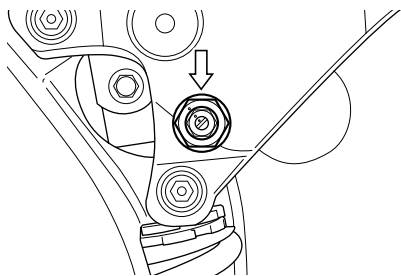

Low stroke speed damping force adjuster ③

To adjust the damping force, turn the adjuster in fully and then turn it out. The fully turned-in position provides the stiffest damping force and turning the adjuster out will soften the damping force. Count the number of turns from the fully turned-in position. To set the low stroke speed damping force to the standard position, turn the adjuster clockwise until it stops and then turn it counterclockwise 2 and 1/4 turns until the two punch marks align. If the two punch marks do not align by turning out 2 and 1/4 turns, turn in or out the adjuster until two punch marks align.

High stroke speed damping force adjuster ②

To adjust the damping force, turn the adjuster in fully and then turn it out. The fully turned-in position provides the stiffest damping force and turning the adjuster out will soften the damping force. Count the number of turns from the fully turned-in position. To set the high stroke speed damping force to the standard position, turn the adjuster clockwise until it stops and then turn it counterclockwise 3 turns until the two punch marks align. If the two punch marks do not align by turning out 3 turns, turn in or out the adjuster until two punch marks align.

Turn the adjuster clockwise from the standard position to stiffen the damping force. Turn the adjuster counterclockwise to soften the damping force. The damping force should be adjusted gradually, 1/8 turn at a time, to fine-tune the suspension.

FOOTRESTS AND GEARSHIFT LEVER POSITION CHANGE

Right and left footrest position and gearshift lever position can be changed in three positions to sit in a comfortable position.

Right Footrest and Rear Brake Pedal

Change the right footrest position and adjust brake lever position as follows:

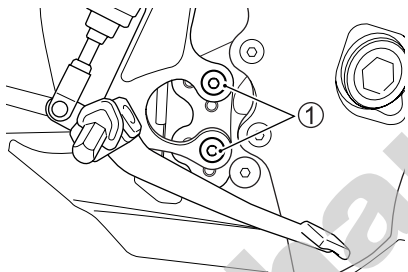

1. Loosen the two footrest mounting bolts ①.

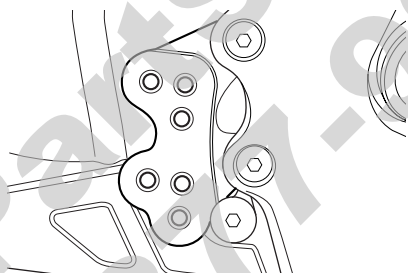

2. Move the footrest bracket and remount it to the desired position.
3. Tighten the bolts to the specified torque.

Footrest bracket
tightening torque:
23 N·m (2.3 kgf-m, 16.5 lbf-ft)

*NOTE: Apply a drop of SUZUKI
THREAD LOCK "1342" to the
footrest mounting bolts ①.*

⚠ WARNING

Failure to torque bolts and nuts properly could lead to an accident.

Torque bolts and nuts to the proper specifications. If you are not sure of the proper procedure, have your authorized SUZUKI dealer or a qualified mechanic do this.

4. Adjust the rear brake pedal height by referring to the REAR BRAKE PEDAL ADJUSTMENT section in this manual.

Left Footrest and Gearshift Lever

Change the left footrest position and gearshift lever position as follows:

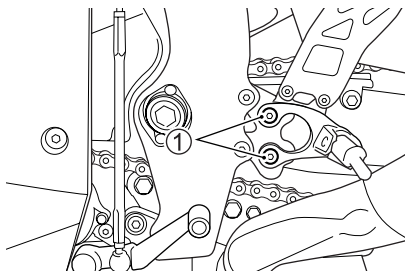

1. Loosen the two footrest mounting bolts ①.

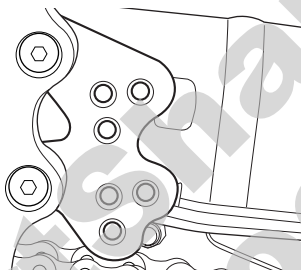

2. Move the footrest bracket and remount it to the desired position.
3. Tighten the bolts to the specified torque.

Footrest bracket
tightening torque:
23 N·m (2.3 kgf·m, 16.5 lbf·ft)

NOTE: Apply a drop of SUZUKI THREAD LOCK "1342" to the footrest mounting bolts ①.

WARNING

Failure to torque bolts and nuts properly could lead to an accident.

Torque bolts and nuts to the proper specifications. If you are not sure of the proper procedure, have your authorized SUZUKI dealer or a qualified mechanic do this.

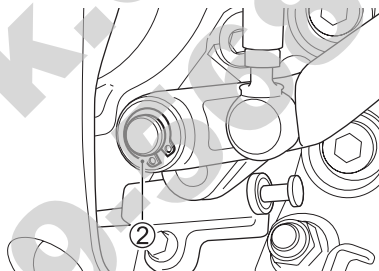

4. Remove the circlip ② with snap ring pliers. Remove the gearshift lever.

NOTE: Replace with a new circlip when refitting it.

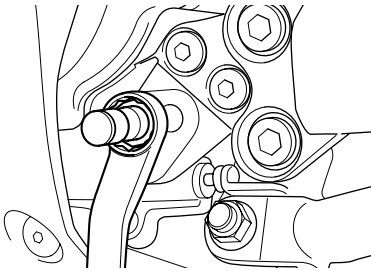

5. Loosen the gearshift lever pivot.

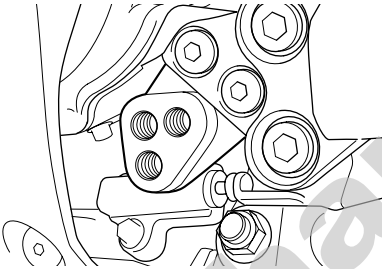

6. Move the gearshift lever pivot and refit it to the desired position. Tighten the pivot bolt securely.

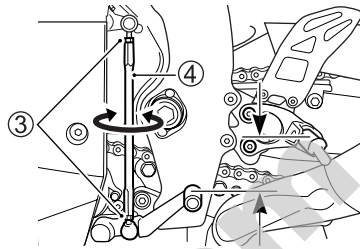

65 - 75 mm
(2.6 - 3.0 in)

7. Loosen the lock nuts (3). Turn the rod (4) and adjust the gearshift lever position.
8. Rotate the rod (4) to locate the gearshift lever 65 - 75 mm (2.6 - 3.0 in) below the top face of the footrest.
9. Tighten the lock nuts to secure the rod in the proper position.

BREAK-IN AND INSPECTION BEFORE RIDING

BREAK-IN	4-2
INSPECTION BEFORE RIDING	4-3

BREAK-IN AND INSPECTION BEFORE RIDING

BREAK-IN

The first 800 km (500 miles) is the most important in the life of your motorcycle. Proper operation during this break-in period will help assure maximum life and performance from your new motorcycle. The following guidelines explain proper break-in procedures.

Maximum Engine Speed Recommendation

The table below shows the maximum engine speed recommendation during the break-in period.

Initial 800 km (500 miles)	Below 6500 r/min
Up to 1600 km (1000 miles)	Below 10000 r/min
Over 1600 km (1000 miles)	Below 13750 r/min

Vary the Engine Speed

Vary the engine speed during the break-in period. This allows the parts to “load” (aiding the mating process) and then “unload” (allowing the parts to cool). Although it is essential to place some stress on the engine components during break-in, you must be careful not to load the engine too much.

Breaking in the New Tires

New tires need proper break-in to assure maximum performance, just as the engine does. Wear-in the tread surface by gradually increasing your cornering lean angles over the first 160 km (100 miles) before attempting maximum performance. Avoid hard acceleration, hard cornering, and hard braking for the first 160 km (100 miles).

WARNING

Failure to perform break-in of the tires could cause tire slip and loss of control.

Use extra care when riding on new tires. Perform proper break-in of the tires as described in this section and avoid hard acceleration, hard cornering, and hard braking for the first 160 km (100 miles).

Allow the Engine Oil to Circulate before Riding

Allow enough idling time after warm or cold engine start up before revving the engine or placing the transmission in gear. This allows time for the lubricating oil to reach all critical engine components.

Observe Your Initial and Most Critical Service

The initial service (break-in maintenance) is the most important service your motorcycle will receive. During break-in operation, all of the engine components will have mated together and seated. Maintenance required as part of the initial service includes correction of all adjustments, tightening of all fasteners and replacement of dirty oil. Timely performance of this service will help make sure you get the best service life and performance from the engine.

INSPECTION BEFORE RIDING

WARNING

Failure to inspect and maintain your motorcycle properly increases the chance of an accident or equipment damage.

Always perform a pre-ride inspection before each ride. Refer to the table on page 4-4 for check items. For further details, refer to the INSPECTION AND MAINTENANCE section.

WARNING

Using worn, improperly inflated, or incorrect tires will reduce stability and can cause an accident.

Follow all instructions in the TIRES section in this owner's manual.

Check the condition of the motorcycle to help make sure that you do not have mechanical problems or get stranded somewhere when you ride. Before riding the motorcycle, be sure to check the following items. Be sure your motorcycle is in good condition for the personal safety of the rider, passenger and protection of the motorcycle.

▲ WARNING

Checking maintenance items when the engine is running can be hazardous. You could be severely injured if your hands or clothing get caught in moving parts.

Shut the engine off when performing maintenance checks, except when checking the engine stop switch and throttle.

WHAT TO CHECK	CHECK FOR:
Steering	<ul style="list-style-type: none"> • Smoothness • No restriction of movement • No play or looseness
Throttle	<ul style="list-style-type: none"> • Correct play in the throttle cable • Smooth operation and positive return of the throttle grip to the closed position
Clutch	<ul style="list-style-type: none"> • Correct lever play • Smooth and progressive action
Brakes	<ul style="list-style-type: none"> • Proper pedal and lever operation • Fluid level in the reservoir to be above "LOWER" line • Correct pedal and lever play • No "sponginess" • No fluid leakage • Brake pads not to be worn down to the limit line
Suspension	Smooth movement
Fuel	Enough fuel for the planned distance of operation
Drive chain	<ul style="list-style-type: none"> • Correct tension or slack • Adequate lubrication • No excessive wear or damage
Tires	<ul style="list-style-type: none"> • Correct pressure • Adequate tread depth • No cracks or cuts
Engine oil	Correct level
Cooling system	<ul style="list-style-type: none"> • Proper coolant level • No coolant leakage
Lighting	Operation of all lights and indicators
Horn	Correct function
Engine stop switch	Correct function
Side stand/ Ignition interlock switch	Proper operation

RIDING TIPS

STARTING THE ENGINE	5-2
STARTING OFF	5-3
USING THE TRANSMISSION	5-4
RIDING ON HILLS	5-5
STOPPING AND PARKING	5-5
CARRYING A PASSENGER	5-7

RIDING TIPS

STARTING THE ENGINE

Before attempting to start the engine, make sure:

1. The transmission is in neutral.
2. The engine stop switch is in the "Ⓞ" position.

NOTE: This motorcycle has a starter interlock system for the ignition and starter circuit. The engine can only be started if:

- *The transmission is in neutral and the clutch is disengaged, or*
- *The transmission is in gear, the side stand is fully up and the clutch is disengaged.*

When the Engine is Cold:

1. Close the throttle completely and push the electric starter button.
2. After the engine starts, let the engine run until the engine sufficiently warms up.

When a Cold Engine is Hard to Start:

1. Open the throttle approximately 1/8 turn and push the electric starter button.
2. After the engine starts, let the engine run until the engine sufficiently warms up.

When the Engine is Warm:

Close the throttle completely and push the electric starter button.

When a Warm Engine is Hard to Start:

Open the throttle approximately 1/8 turn and push the electric starter button.

⚠ WARNING

Running the engine indoors or in a garage can be hazardous. Exhaust gas contains carbon monoxide, a gas that is colorless and odorless and can cause death or severe injury.

Only run the engine outdoors where there is fresh air.

CAUTION

Running the engine too long without riding may cause the engine to overheat. Overheating can result in damage to internal engine components and discoloration of exhaust pipes.

Shut the engine off if you cannot begin your ride promptly.

STARTING OFF

WARNING

Riding this motorcycle at excessive speed increases your chances of losing control of the motorcycle. This may result in an accident.

Always ride within the limits of your skills, your motorcycle, and the riding conditions.

WARNING

Removing your hands from the handlebars or feet from the footrests during operation can be hazardous. If you remove even one hand or foot from the motorcycle, you can reduce your ability to control the motorcycle.

Always keep both hands on the handlebars and both feet on the footrests of your motorcycle during operation.

WARNING

Sudden side winds, which can occur when being passed by larger vehicles, at tunnel exits or in hilly areas, can upset your control.

Reduce your speed and be alert to side winds.

Make sure that the side stand is in the fully up position. Squeeze the clutch lever and pause momentarily. Engage first gear by depressing the gearshift lever downward. Turn the throttle grip toward you and at the same time release the clutch lever gently and smoothly. As the clutch engages, the motorcycle will start moving forward. To shift to the next higher gear, accelerate gently, then close the throttle and squeeze the clutch lever simultaneously. Lift the gear shift lever upward to select the next gear and release the clutch lever as you open the throttle again. Select higher gears in this manner until top gear is reached.

NOTE: This motorcycle has a side stand/ignition interlock switch. If you shift the transmission into gear when the side stand is down, the engine will stop running.

USING THE TRANSMISSION

The transmission is provided to keep the engine operating smoothly in its normal operating speed range. The gear ratios have been carefully chosen to meet the characteristics of the engine. The rider should always select the most suitable gear for the prevailing conditions. Never slip the clutch to control road speed, but rather downshift to allow the engine to run within its normal operational range. The table below shows the approximate speed range for each gear.

Shifting up schedule

Gear position	miles/h	km/h
1st → 2nd	12	20
2nd → 3rd	19	30
3rd → 4th	25	40
4th → 5th	31	50
5th → 6th	37	60

Shifting down schedule

Gear position	miles/h	km/h
6th → 5th	31	50
5th → 4th	25	40
4th → 3rd	19	30

Disengage the clutch when the motorcycle speed drops below 12 miles/h (20 km/h).

WARNING

Downshifting when engine speed is too high can:

- cause the rear wheel to skid and lose traction due to increased engine braking, resulting in an accident; or
- force the engine to overrev in the lower gear, resulting in engine damage.

Reduce speed before downshifting.

WARNING

Downshifting while the motorcycle is leaned over in a corner may cause rear wheel skid and loss of control.

Reduce your speed and downshift before entering a corner.

CAUTION

Revvng the engine into the red zone can cause severe engine damage.

Never allow the engine to rev into the red zone in any gear.

RIDING ON HILLS

- When climbing steep hills, the motorcycle may begin to slow down and show lack of power. At this point you should shift to a lower gear so that the engine will again be operating in its normal power range. Shift rapidly to prevent the motorcycle from losing momentum.
- When descending a long, steep slope, use engine compression to assist the brakes by shifting to a lower gear. Continuous brake application can overheat the brakes and reduce their effectiveness.
- Be careful, however, not to allow the engine to overrev.

STOPPING AND PARKING

1. Twist the throttle grip away from yourself to close the throttle completely.
2. Apply the front and rear brakes evenly and at the same time.
3. Downshift through the gears as road speed decreases.
4. Select neutral with the clutch lever squeezed toward the grip (disengaged position) just before the motorcycle stops. Neutral position can be confirmed by observing the neutral indicator light.

WARNING

Inexperienced riders tend to underutilize the front brake. This can cause excessive stopping distance and lead to a collision. Using only the front or rear brake can cause skidding and loss of control.

Apply both brakes evenly and at the same time.

WARNING

Hard braking while turning may cause wheel skid and loss of control.

Brake before you begin to turn.

⚠ WARNING

Hard braking on wet, loose, rough, or other slippery surfaces can cause wheel skid and loss of control.

Brake lightly and with care on slippery or irregular surfaces.

⚠ WARNING

Following another vehicle too closely can lead to a collision. As vehicle speeds increase, stopping distance increases progressively.

Be sure you have a safe stopping distance between you and the vehicle in front of you.

5. Park the motorcycle on a firm, flat surface where it will not fall over.

⚠ WARNING

A hot muffler can burn you. The muffler will be hot enough to burn you for some time after stopping the engine.

Park the motorcycle where pedestrians or children are not likely to touch the muffler.

NOTE: If the motorcycle is to be parked on the side stand on a slight slope, the front end of the motorcycle should face "up" the incline to avoid rolling forward off the side stand. You may leave the motorcycle in 1st gear to help prevent it from rolling off the side stand. Shift to neutral before starting engine.

6. Turn the ignition switch to the "OFF" position.
7. Turn the handlebars all the way to the left and lock the steering for security.
8. Remove the ignition key.

NOTE: If an optional anti-theft lock such as U-shape lock, brake disk lock and chain is used to avoid theft, be sure to remove anti-theft lock before moving the motorcycle.

CARRYING A PASSENGER

Before you invite someone to be a passenger on your motorcycle, you need to be thoroughly familiar with motorcycle operation. Adjust tire pressures and suspension according to the Tire Pressure and Loading section and the Suspension section of this manual.

The passenger should always hold onto your waist or hips, or onto the seat strap or grab bar, as equipped. Ask your passenger not to make any sudden movements. When you lean going around a corner, the passenger should lean with you. The passenger should always keep his or her feet on the footrests, even when you are stopped at a light.

To help prevent burn injuries, warn your passenger not to contact the muffler when mounting or dismounting your motorcycle.



PartShark.com
877-999-5686



ACCESSORY USE AND MOTORCYCLE LOADING

ACCESSORY USE	6-2
MODIFICATION	6-4

ACCESSORY USE AND MOTORCYCLE LOADING

ACCESSORY USE

The addition of unsuitable accessories can lead to unsafe operating conditions. It is not possible for Suzuki to test each accessory on the market or combinations of all the available accessories; however, your dealer can assist you in selecting quality accessories and installing them correctly. Use extreme caution when selecting and installing the accessories on your motorcycle and consult your Suzuki dealer if you have any questions.

WARNING

Improper accessory installation can make your motorcycle unsafe and can lead to an accident.

Use Suzuki genuine accessories or equivalent, designed and tested for your motorcycle. Follow the guidelines in this section.

Accessory installation guideline

- Install aerodynamic affecting accessories, such as a fairing, windshield, backrests, saddlebags, and travel trunks, as low as possible, as close to the motorcycle and as near the center of gravity as is feasible. Check that the mounting brackets and other attachment hardware are rigidly mounted.
- Inspect for proper ground clearance and bank angle. Inspect that the accessory does not interfere with the operation of the suspension, steering or other control operations.

- Accessories fitted to the handlebars or the front fork area can create serious stability problems. This extra weight will cause the motorcycle to be less responsive to your steering control. The weight may also cause oscillations in the front end and lead to instability problems. Accessories added to the handlebars or front fork of the machine should be as light as possible and kept to a minimum.
- Select an accessory which does not limit the freedom of rider movement.
- Select an electric accessory which does not exceed motorcycle's electrical system capacity. Severe overloads may damage the wiring harness or create hazardous situations.
- Do not pull a trailer or sidecar. This motorcycle is not designed to pull a trailer or sidecar.

Loading Limit

WARNING

Overloading or improper loading can cause loss of motorcycle control and this may result in an accident.

Follow loading limits and loading guidelines in this manual.

- Never exceed the G.V.W. (Gross Vehicle Weight) of this motorcycle. The G.V.W. is the combined weight of the machine, accessories, payload, rider and passenger. When selecting your accessories, keep in mind the weight of the rider as well as the weight of the accessories. The additional weight of the accessories may not only create an unsafe riding condition but may also affect the riding stability.

G.V.W.: 390 kg (860 lbs)
at the tire pressure (cold)
Front: 250 kPa
(2.50 kgf/cm², 36 psi)
Rear: 290 kPa
(2.90 kgf/cm², 42 psi)

Loading Guidelines

This motorcycle is primarily intended to carry small items when you are not riding with a passenger. Follow the guidelines below to carry a passenger or cargo:

- Balance the load between the left and right side of the motorcycle and fasten it securely.
- Place cargo weight as close to the center of the motorcycle as possible.
- Do not attach large or heavy items to the handlebars, front forks or rear fender.
- Check that both tires are properly inflated to the specified tire pressure for your loading conditions. Refer to page 7-33.
- Improperly loading your motorcycle can reduce your ability to balance and steer the motorcycle. You should ride at reduced speeds, less than 130 km/h (80 mph), when the cargo is loaded or accessory is fitted.
- Adjust suspension setting as necessary.

MODIFICATION

Modification of the motorcycle, or removal of original equipment may render the vehicle unsafe or illegal. Obey all applicable equipment regulations in your area.

The frame of this motorcycle is made of an aluminum alloy. Therefore, never make any modifications such as drilling or welding to the frame as it weakens the frame significantly. This could result in an unsafe vehicle operating condition and subsequent accident. Suzuki will not be responsible in any way for personal injury or damage to the motorcycle caused by frame modifications.

Bolt-on-accessories that do not modify the frame in any way may be installed, provided that the loading limit is not exceeded. For loading limit, refer to the ACCESSORY USE AND MOTORCYCLE LOADING section of the owner's manual.

WARNING

Modification to an aluminum alloy frame, such as drilling or welding, weakens the frame. This could result in an unsafe operating condition and may lead to an accident.

Never make any modifications to the frame.

INSPECTION AND MAINTENANCE

NOTICE	7-2
MAINTENANCE SCHEDULE	7-2
TOOLS	7-5
STEERING DAMPER MAINTENANCE	7-5
LUBRICATION POINTS	7-6
BATTERY	7-7
AIR CLEANER	7-9
SPARK PLUGS	7-12
ENGINE OIL	7-16
ENGINE IDLE SPEED INSPECTION	7-20
THROTTLE CABLE PLAY	7-21
FUEL HOSE	7-21
CLUTCH ADJUSTMENT	7-22
ENGINE COOLANT	7-22
DRIVE CHAIN	7-24
BRAKES	7-28
TIRES	7-32
SIDE STAND/IGNITION INTERLOCK SWITCH	7-36
FRONT WHEEL REMOVAL	7-37
REAR WHEEL REMOVAL	7-40
LIGHT BULB REPLACEMENT	7-42
FUSES	7-48

INSPECTION AND MAINTENANCE

NOTICE

MAINTENANCE, REPLACEMENT OR REPAIR OF THE EMISSION CONTROL DEVICES AND SYSTEMS MAY BE PERFORMED BY ANY MOTORCYCLE REPAIR ESTABLISHMENT OR INDIVIDUAL USING ANY MOTORCYCLE PART WHICH HAS BEEN CERTIFIED UNDER THE PROVISIONS IN THE CLEAN AIR ACT Sec. 207 (a)(2).

MAINTENANCE SCHEDULE

It is very important to inspect and maintain your motorcycle regularly. Follow the guidelines in the chart. The intervals between periodic services in kilometers, miles and months are shown. At the end of each interval, be sure to perform the maintenance listed.

WARNING

Improper maintenance or failure to perform recommended maintenance increases the chance of an accident or motorcycle damage.

Always follow the inspection and maintenance recommendations and schedules in this owner's manual. Ask your SUZUKI dealer or a qualified mechanic to do the maintenance items marked with an asterisk (*). You may perform the unmarked maintenance items by referring to the instructions in this section, if you have mechanical experience. If you are not sure how to do any of the jobs, have your SUZUKI dealer or a qualified mechanic do them.

▲ WARNING

Running the engine indoors or in a garage can be hazardous. Exhaust gas contains carbon monoxide, a gas that is colorless and odorless and can cause death or severe injury.

Only run the engine outdoors where there is fresh air.

NOTE: The MAINTENANCE CHART specifies the minimum requirements for maintenance. If you use your motorcycle under severe conditions, perform maintenance more often than shown in the chart. If you have any questions regarding maintenance intervals, consult your SUZUKI dealer or a qualified mechanic.



CAUTION

Using poor quality replacement parts can cause your motorcycle to wear more quickly and may shorten its useful life.

Use only genuine Suzuki replacement parts or their equivalent.

MAINTENANCE CHART

Interval: This interval should be judged by odometer reading or number of months, whichever comes first.

Element	Interval					
	km	1000	6000	12000	18000	24000
	miles	600	4000	7500	11000	14500
	months	2	12	24	36	48
Air cleaner element		–	I	I	R	I
* Exhaust pipe bolts and muffler bolts		T	–	T	–	T
* Exhaust control valve		I	–	I	–	I
* Valve clearance		–	–	–	–	I
Spark plugs		–	I	R	I	R
Fuel line		–	I	I	I	I
* Evaporative emission control system (California model only)		–	–	I	–	I
Engine oil		R	R	R	R	R
Engine oil filter		R	–	–	R	–
Throttle cable play		I	I	I	I	I
* PAIR (air supply) system		–	–	I	–	I
* Throttle valve synchronization		I (CA. only)	–	I	–	I
* Engine coolant		Replace every 2 years				
Radiator hose		–	I	I	I	I
Clutch cable play		–	I	I	I	I
Drive chain		I	I	I	I	I
		Clean and lubricate every 1000 km (600 miles)				
* Brakes		I	I	I	I	I
Brake fluid		–	I	I	I	I
		*Replace every 2 years				
Brake hose		–	I	I	I	I
		*Replace every 4 years				
Tires		–	I	I	I	I
* Steering		I	–	I	–	I
* Front forks		–	–	I	–	I
* Rear suspension		–	–	I	–	I
* Chassis bolts and nuts		T	T	T	T	T

NOTE: I= Inspect and clean, adjust, replace or lubricate as necessary, R= Replace, T= Tighten

NOTE: (California model only) and (CA. only) means that the items or the maintenance interval is to be applied only for the California model.

TOOLS

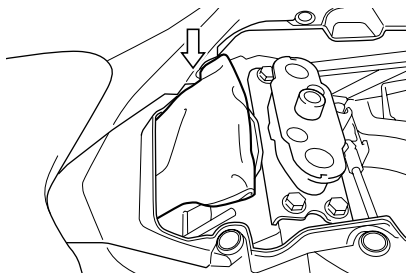

A tool kit is provided with your motorcycle. It is located under the rear seat.

NOTE: Insert the tool kit into the tool case properly, or the rear seat can not be set and locked.

STEERING DAMPER MAINTENANCE

1. Keep the steering damper shaft ① clean at all times.
2. Wipe off any oil residue with a cloth.

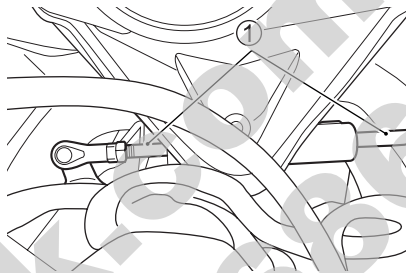

NOTE:

- Do not confuse the grease-like residue on the steering damper's shaft with an oil leak. Collection of this residue is normal and is from oil seal lubricant used in the damper.
- You may also notice a sound as the damper shaft is stroked in and out. This "escaping air" type sound is normal and is made as the internal valving damps the shaft movement.

LUBRICATION POINTS

Proper lubrication is important for smooth operation and long life of each working part of your motorcycle and also for safe riding. It is a good practice to lubricate the motorcycle after a long rough ride and after getting it wet in the rain or after washing it. Major lubrication points are indicated below.

CAUTION

Lubricating switches can damage the switches.

Do not apply grease and oil to the switches.

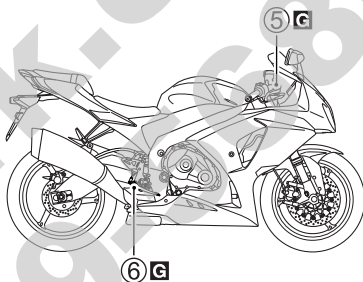
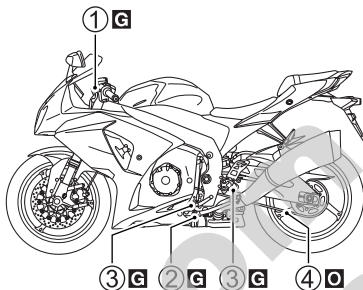

- ◻ Motor oil
- ◼ Grease

- ① Clutch lever holder
- ② Side stand pivot and spring hook
- ③ Gearshift lever pivot and footrest pivot
- ④ Drive chain
- ⑤ Brake lever holder
- ⑥ Brake pedal pivot and footrest pivot

BATTERY

This battery is a sealed type battery and requires no maintenance. Have your dealer check the battery's state of charge periodically.

The standard charging rate is $1.2A \times 5$ to 10 hours and the maximum rate is $5.0A \times 1$ hour. Never exceed maximum charging rate.

⚠ WARNING

Battery posts, terminals, and related accessories contain lead and lead compounds.

Wash hands after handling.

⚠ WARNING

Hydrogen gas produced by batteries can explode if exposed to flames or sparks.

Keep flames and sparks away from the battery. Never smoke when working near the battery.

CAUTION

Exceeding the maximum charging rate for the battery can shorten its life.

Never exceed the maximum charging rate.

Battery Removal

To remove the battery, follow procedure below:

1. Place the motorcycle on the side stand.
2. Remove the front seat by referring to the SEAT LOCK AND HELMET HOLDERS section.

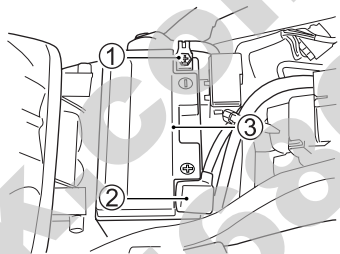

3. Disconnect the negative (-) terminal ①.
4. Remove the cap. Disconnect the positive (+) terminal ②.
5. Remove the battery ③.

To install the battery:

1. Install the battery in the reverse order of removal.
2. Connect the battery terminals securely.

NOTE: Be sure to reset the engine rpm indicator in the instrument panel when the battery terminals are reconnected.

CAUTION

Reversing the battery lead wires can damage the charging system and the battery.

The red lead must go to the positive (+) terminal and the black (or black with white tracer) lead must go to the negative (-) terminal.

⚠ WARNING

Batteries contain toxic substances including sulfuric acid and lead. They could have potential negative consequences for the environment and human health.

Used battery must be disposed or recycled according to the local law and must not be discarded with ordinary household waste. Make sure not to tip over the battery when you remove it from the motorcycle. Otherwise, sulfuric acid could run out and you might get injury.

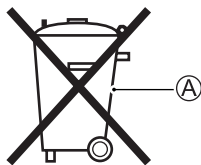

Pb — (B)

The crossed-out wheeled bin symbol (A) located on the battery label indicates that used battery should be collected separately from ordinary household waste. The chemical symbol of "Pb" (B) indicates the battery contains more than 0.004% lead.

By ensuring the used battery is disposed or recycled correctly, you will help prevent potential negative consequences for the environment and human health, which could otherwise be caused by inappropriate waste handling of the battery. The recycling of materials will help to conserve natural resources. For more detailed information about disposing or recycling of the used battery, consult your Suzuki dealer.

AIR CLEANER

The air cleaner element must be kept clean to provide good engine power and gas mileage. If you use your motorcycle under normal low-stress conditions, you should service the air cleaner at the intervals specified. If you ride in dusty, wet, or muddy conditions, you will need to inspect the air cleaner element much more frequently. Use the following procedure to remove the element and inspect it.

WARNING

Operating the engine without the air cleaner element in place could allow a flame to spit back from the engine to the air cleaner, or could allow dirt to enter the engine. This could cause a fire or severe engine damage.

Never run the engine without the air cleaner element properly installed.

CAUTION

Inspect or replace the air cleaner element frequently if the motorcycle is used in dusty, wet or muddy conditions. The air cleaner element will clog under these conditions, and this may cause engine damage, poor performance, and poor fuel economy.

Clean the air cleaner case and inspect the element immediately if water gets in the air cleaner box.

Air Cleaner Element Removal

1. Place the motorcycle on the side stand.
2. Remove the front seat by referring to the SEAT LOCK AND HELMET HOLDERS section.

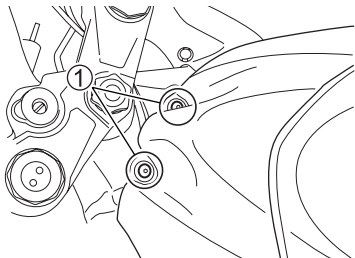

3. Remove the fuel tank fitting bolts ①.

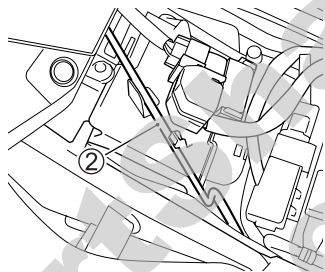

4. Remove the prop stay ②.

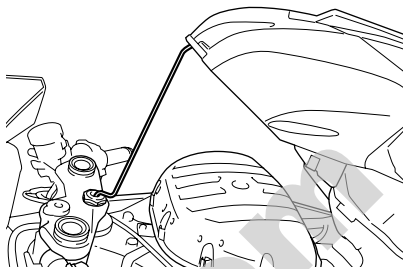

5. Lift the front end of the fuel tank and prop it up as shown above. Insert the crank end of the prop stay into the hole of the steering shaft.

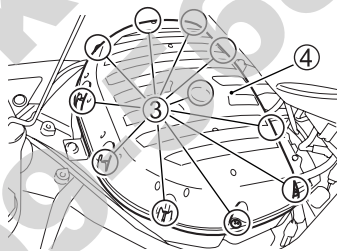

6. Remove the 11 screws ③.
7. Remove the cover ④.

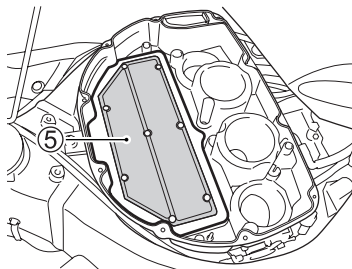

8. Remove the air cleaner element ⑤.

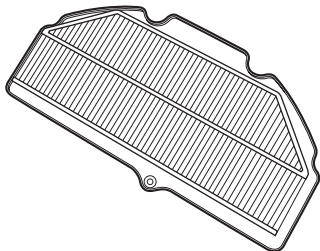

9. Inspect the air cleaner element condition. Replace the air cleaner element periodically.

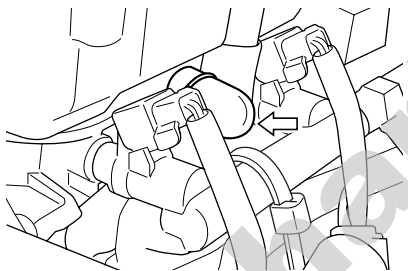

10. Remove the plug and drain water and oil at the periodic maintenance interval. The air cleaner drain plug is located beneath the air cleaner box.

Installation

Reinstall the air cleaner element in reverse order of removal.

CAUTION

A torn air cleaner element will allow dirt to enter the engine and can damage the engine.

Carefully examine the air cleaner element for tears during cleaning. Replace it with a new one if it is torn.

CAUTION

Failure to position the air cleaner element properly can allow dirt to bypass the air cleaner element. This will cause engine damage.

Be sure to properly install the air cleaner element.

SPARK PLUGS

Your motorcycle comes equipped with NGK CR9EIA-9 or DENSO IU27D spark plugs. To determine if the standard spark plug is right for your usage, check the color of the plug's porcelain center electrode insulator after motorcycle operation. A light brown color indicates that the plug is correct. A white or dark insulator indicates that the engine may need adjustment, or another plug type may be needed. Consult your Suzuki dealer or a qualified mechanic if your plug insulator is not a light brown color.

CAUTION

An improper spark plug may have an incorrect fit or heat range for your engine. This may cause severe engine damage which will not be covered under warranty.

Use one of the spark plugs listed below or equivalent. Consult your Suzuki dealer or a qualified mechanic if you are not sure which spark plug is correct for your type of usage.

Plug Replacement Guide

NGK	DENSO	REMARKS
CR8EIA-9	IU24D	If the standard plug is apt to get wet, replace with this plug.
CR9EIA-9	IU27D	Standard
CR10EIA-9	IU31D	If the standard plug is apt to overheat, replace with this plug.

NOTE: If the above-named plugs are not available, consult your Suzuki dealer.

NOTE: This motorcycle uses resistor-type spark plug to avoid jamming electronic parts. Improper spark plug selection may cause electronic interference with your motorcycle's ignition system, resulting in motorcycle performance problems. Use only the recommended spark plugs.

Spark Plug Removal

1. Lift the fuel tank and remove the air cleaner cover by referring to the AIR CLEANER section.

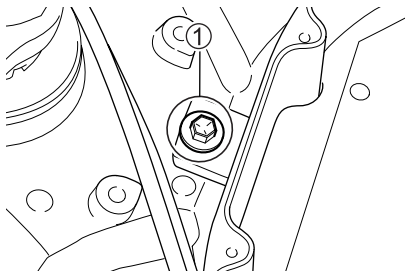

2. Remove the bolt ①.

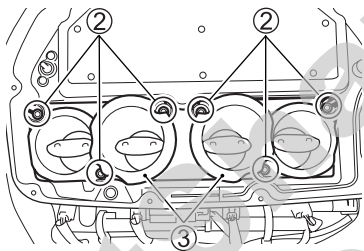

3. Remove the bolts ② and two funnels ③.

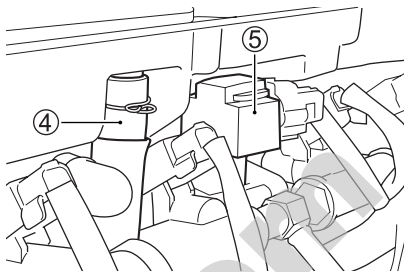

4. Pull out the tube ④. Disconnect the air cleaner sensor assembly ⑤.

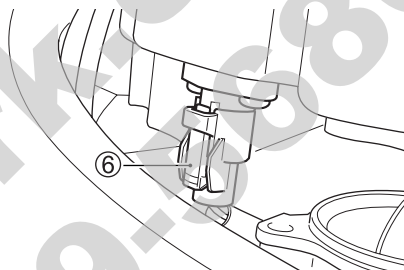

5. Disconnect the coupler ⑥.

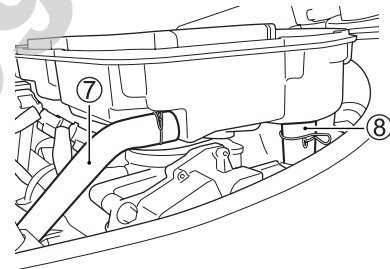

6. Pull out the tubes ⑦, ⑧.
7. Remove the air cleaner box.

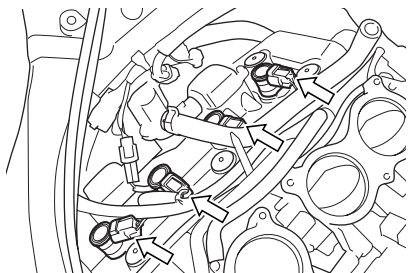

8. Release the coupler locks and disconnect the couplers from the ignition coils.

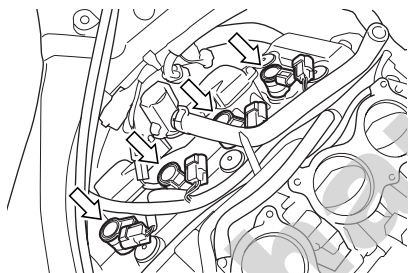

9. Pull off the ignition coils.

CAUTION

Improper removal of ignition coils can damage the ignition coils.

Pull off the ignition coils with your hand. Do not use pliers.

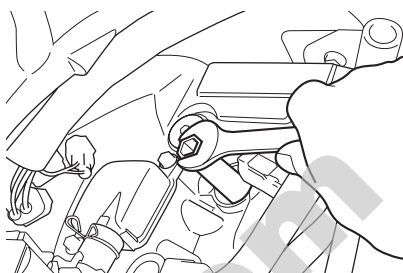

10. Remove the spark plugs with a spark plug wrench.

CAUTION

Dirt can damage your engine if it enters an open spark plug hole.

Cover the spark plug hole whenever the spark plug is removed.

Spark Plug Inspection

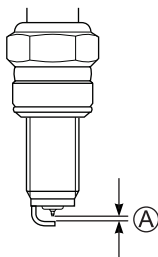

Measure the spark plug gap \textcircled{A} with a wire type feeler gauge. The standard spark plug gap is 0.8 – 0.9 mm (0.031 – 0.035 in). If the measured spark plug gap is out of standard range, replace the spark plug with a new one.

Installation

To install a spark plug, turn it in as far as possible with your fingers, then tighten it with a wrench.

CAUTION

A crossthreaded or overtightened spark plug will damage the aluminum threads of the cylinder head.

Follow the procedure below to tighten the spark plug properly.

Carefully turn the spark plug by hand into the threads until it is finger tight. If the spark plug is new, tighten it with a wrench about 1/2 turn past finger tight. If you are reusing the old spark plug, tighten it with a wrench about 1/8 turn past finger tight.

CAUTION

Improper installation of ignition coils can damage the ignition coils.

Install the ignition coils with your hand. Never hit the ignition coils with a tool.

Reinstall the air cleaner box and fuel tank in the reverse order of removal.

ENGINE OIL

Engine life depends on oil amount and quality. Daily oil level checks and periodic changes are two of the most important maintenance items to be performed.

Engine Oil Level Check

Check the engine oil level as follows:

1. Place the motorcycle on level ground on the side stand.
2. Start the engine and allow it to idle for a few minutes.
3. Stop the engine and wait 3 minutes.

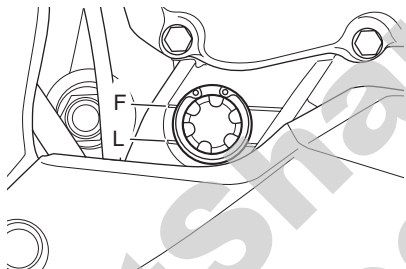

4. Hold the motorcycle vertically and check the oil level through the oil level inspection window on the right side of the engine. The engine oil level should be between "L" (low) and "F" (full) lines.

CAUTION

The engine oil level must be between the "L" (Low) line and "F" (Full) line, or engine damage may occur.

Check the oil level, through the inspection window, with the motorcycle held vertically on level ground before each use of the motorcycle.

Engine Oil and Filter Change

Change the engine oil and oil filter at the scheduled times. The engine should always be warm when the oil is changed so the oil will drain easily. The procedure is as follows:

1. Place the motorcycle on the side stand.



2. Remove the oil filler cap ①.

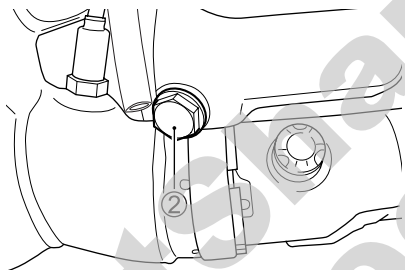

3. Remove the drain plug ② from the bottom of the engine and drain the engine oil into a drain pan.

⚠ WARNING

Engine oil and exhaust pipes can be hot enough to burn you.

Wait until the oil drain plug and exhaust pipes are cool enough to touch with bare hands before draining oil.

⚠ WARNING

New and used oil can be hazardous. Children and pets may be harmed by swallowing new or used oil. Repeated, prolonged contact with used engine oil may cause skin cancer. Brief contact with used oil may irritate skin.

- Keep new and used oil away from children and pets.
- Wear a long-sleeve shirt and waterproof gloves.
- Wash with soap if oil contacts your skin.

NOTE: Recycle or properly dispose of used oil.

4. Reinstall the drain plug and gasket. Tighten the plug securely with a wrench.

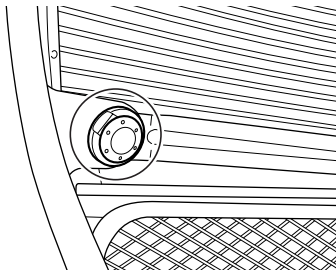

5. Remove the fastener.

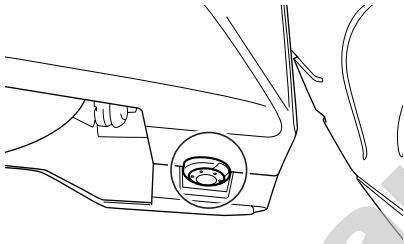

6. Remove the fastener.

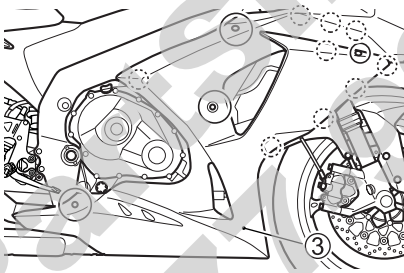

7. Remove the bolts and hooks of the right fairing ③.

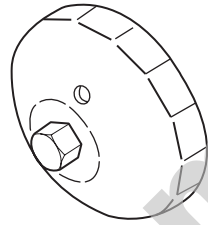

Available from Suzuki dealer
Oil filter wrench (Part No. 09915-40620)

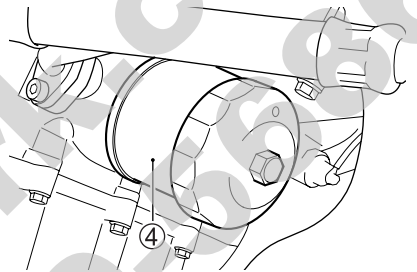

8. Turn the oil filter ④ counter-clockwise and remove it with a Suzuki “cap type” oil filter wrench or a “strap type” filter wrench of the proper size.

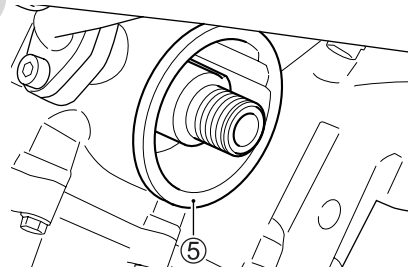

9. Wipe off the mounting surface ⑤ on the engine where the new filter will be seated with a clean rag.

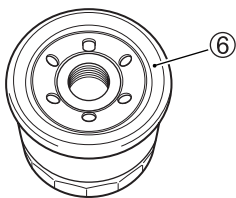

10. Smear a little engine oil around the rubber gasket ⑥ of the new oil filter.
11. Screw the new filter by hand until the filter gasket contacts the mounting surface (small resistance will be felt).

CAUTION

Using an oil filter with the wrong design or thread specifications can cause oil leaks or engine damage.

Use a genuine SUZUKI oil filter or an equivalent filter designed for your motorcycle.

NOTE: To tighten the oil filter properly, it is important to accurately identify the position at which the filter gasket first contacts the mounting surface.

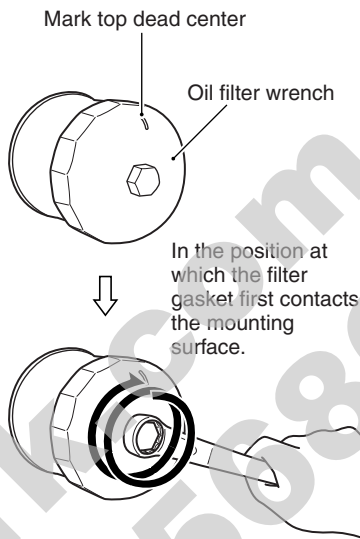

Tighten the filter 2 turns or to specified torque.

12. Mark the top dead center position on the "cap type" filter wrench or on the oil filter. Use an oil filter wrench to tighten the filter 2 turns or to specified torque.

Oil filter tightening torque:
20 N·m (2.0 kgf-m, 14.5 lbf-ft)

13. Pour 3300 ml (3.5 US qt) of new engine oil through the filler hole and install the filler cap. Be sure to always use the specified engine oil described in the FUEL, ENGINE OIL AND COOLANT RECOMMENDATIONS section.

NOTE: About 2800 ml (3.0 US qt) of oil will be required when changing oil only.

CAUTION

Engine damage may occur if you use oil that does not meet Suzuki's specifications.

Use the oil specified in the FUEL, ENGINE OIL AND COOLANT RECOMMENDATIONS section.

14. Reinstall the oil filler cap.
15. Start the engine (while the motorcycle is outside on level ground) and allow it to idle for a few minutes.
16. Turn the engine off and wait approximately 3 minutes. Recheck the oil level on the engine oil inspection window while holding the motorcycle vertically. If it is lower than the "L" mark, add oil until it reaches the "F" mark. Inspect the area around the drain plug and oil filter for leaks.

ENGINE IDLE SPEED INSPECTION

Inspect the engine idle speed. The engine idle speed should be 1050 – 1250 r/min when the engine is warm.

NOTE: If the engine idle speed is not within the specified range, ask your Suzuki dealer or a qualified mechanic to inspect and repair the motorcycle.

THROTTLE CABLE PLAY

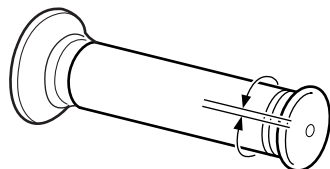
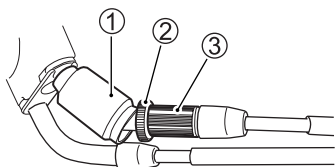

2.0 – 4.0 mm
(0.08 – 0.16 in)

To adjust the cable play:

1. Remove the boot ①.
2. Loosen the lock nut ②.
3. Turn the adjuster ③ so that the throttle grip has 2.0 – 4.0 mm (0.08 – 0.16 in) play.
4. Tighten the lock nut ②.
5. Replace the boot ①.

▲ WARNING

Inadequate throttle cable play can cause engine speed to rise suddenly when you turn the handlebar. This can lead to loss of rider control.

Adjust the throttle cable play so that engine idle speed does not rise due to handlebar movement.

FUEL HOSE

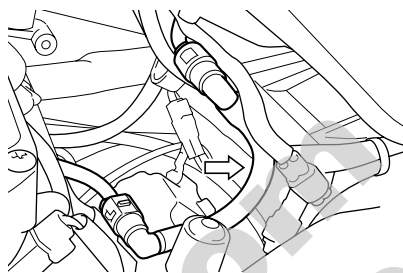

Inspect the fuel hose for damage and fuel leakage. If any defects are found, the fuel hose must be replaced.

CLUTCH ADJUSTMENT

Clutch cable play should be 10 – 15 mm (0.4 – 0.6 in) measured at the clutch lever end. Adjust clutch cable play according to the following procedure:

Minor Adjustment

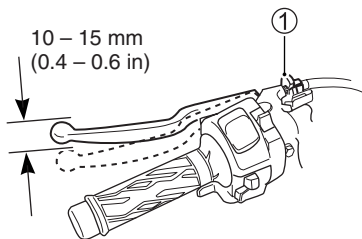

Turn the clutch cable adjuster ① to provide the specified play.

Major Adjustment

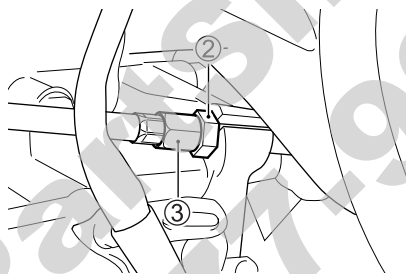

1. Loosen the clutch cable adjuster lock nut ②.
2. Turn the clutch cable adjuster ③ to provide the specified play.
3. Tighten the lock nut ②.

ENGINE COOLANT

Coolant level

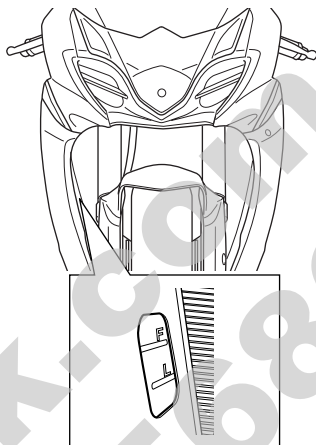

The engine coolant solution should be between the “F” (full) and the “L” (low) level lines on the engine coolant reservoir. If the level is lower than the “L” (low) level line, bring it up to the “F” (full) level by adding a 50:50 mixture of distilled water and engine coolant.

To add mixed coolant:

1. Place the motorcycle on the side stand.
2. Remove the right fairing by referring to the ENGINE OIL section.

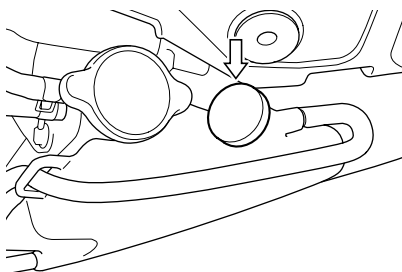

3. Remove the filler cap and add properly mixed coolant through the filler hole until it reaches the "F" line. Refer to the FUEL, ENGINE OIL AND COOLANT RECOMMENDATIONS section.

▲ WARNING

Engine coolant is harmful or fatal if swallowed or inhaled.

Do not drink antifreeze or coolant solution. If swallowed, do not induce vomiting. Immediately contact a poison control center or a physician. Avoid inhaling mist or hot vapors; if inhaled, remove to fresh air. If coolant gets in eyes, flush eyes with water and seek medical attention. Wash thoroughly after handling. Solution can be poisonous to animals. Keep out of the reach of children and animals.

NOTE: Adding only water will dilute the engine coolant and reduce its effectiveness. Add a 50:50 mixture of engine coolant and water.

DRIVE CHAIN

This motorcycle has an endless drive chain constructed from special materials. It does not use a master link. We recommend that you take your motorcycle to an authorized Suzuki dealer if the drive chain needs to be replaced.

The condition and adjustment of the drive chain should be checked each day before you ride. Always follow the guidelines for inspecting and servicing the chain.

WARNING

Riding with the chain in poor condition or improperly adjusted can lead to an accident.

Inspect, adjust, and maintain the chain properly before each ride, according to this section.

Inspecting the Drive Chain

When inspecting the chain, look for the following:

- Loose pins
- Damaged rollers
- Dry or rusted links
- Kinked or binding links
- Excessive wear
- Improper chain adjustment

If you find anything wrong with the drive chain condition or adjustment, correct the problem if you know how. If necessary, consult your authorized Suzuki dealer.

Damage to the drive chain means that the sprockets may also be damaged. Inspect the sprockets for the following:

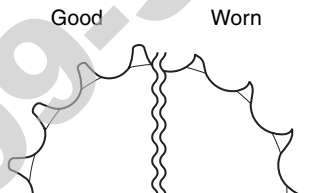

- Excessively worn teeth
- Broken or damaged teeth
- Loose sprocket mounting nuts

If you find any of these problems with your sprocket, consult your Suzuki dealer.

⚠ WARNING

Improperly installing a replacement chain, or using a joint-clip type chain, can be hazardous. An incompletely riveted master link, or a joint-clip type master link, may come apart and cause an accident or severe engine damage.

Do not use a joint-clip type chain. Chain replacement requires a special riveting tool and a high-quality, non-joint-clip type chain. Ask an authorized SUZUKI dealer or a qualified mechanic to perform this work.

Drive Chain Cleaning and Oiling

Clean and oil the chain as follows:

1. Wash the chain with kerosene. Kerosene will lubricate and clean the chain.

⚠ WARNING

Kerosene can be hazardous. Kerosene is flammable. Children or pets may be harmed from contact with kerosene.

Keep flames and smoking materials away from kerosene. Keep children and pets away from kerosene. If swallowed, do not induce vomiting. Call a physician immediately. Dispose of used kerosene properly.

CAUTION

Cleaning the chain with gasoline or commercial cleaning solvents can damage O-rings and ruin the chain.

Clean the drive chain with kerosene only.

2. Allow the chain to dry, then lubricate the links with Suzuki chain lube or an equivalent chain lubricant.

CAUTION

Some drive chain lubricants contain solvents and additives which could damage the O-rings in your chain.

Use Suzuki chain lube or an equivalent chain lubricant that is specifically intended for use with O-ring chains.

Drive Chain Adjustment

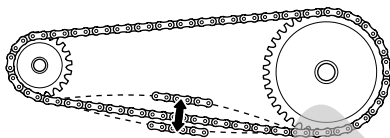

20 – 30 mm
(0.8 – 1.2 in)

Inspect the drive chain slack before each use of the motorcycle. Place the motorcycle on the side stand. The drive chain should be adjusted for 20 – 30 mm (0.8 – 1.2 in) of slack, as shown.

WARNING

Too much chain slack can cause the chain to come off the sprockets, resulting in an accident or serious damage to the motorcycle.

Inspect and adjust the drive chain slack before each use.

To adjust the drive chain, follow the procedure below:

⚠ WARNING

A hot muffler can burn you. The muffler will be hot enough to burn you for some time after stopping the engine.

Wait until the muffler cools to avoid burns.

1. Place the motorcycle on the side stand.

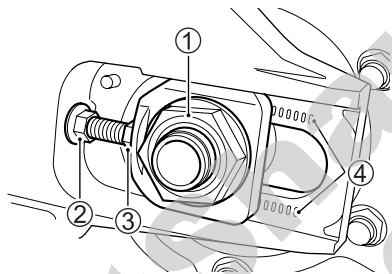

2. Loosen the axle nut ①.
3. Loosen the right and left lock nuts ②.
4. Turn the right and left adjuster bolts ③ until the chain has 20 – 30 mm (0.8 – 1.2 in) of slack halfway between the engine sprocket and rear sprocket.

5. At the same time that the chain is being adjusted, the rear sprocket must be kept in perfect alignment with the front sprocket. To assist you in performing this procedure, there are reference marks ④ on the swingarm and each chain adjuster which are to be aligned with each other and to be used as a reference from one side to the other.
6. Tighten the right and left lock nuts ②.
7. Tighten the axle nut ① securely.
8. Recheck the chain slack after tightening and readjust if necessary.

Rear axle nut tightening torque:
100 N·m (10.0 kgf·m, 72.5 lbf·ft)

NOTE: Do not adjust the drive chain beyond the adjustable range ④. Replace the drive chain before the drive chain exceeds the limit.

BRAKES

This motorcycle has front and rear disk brakes.

⚠ WARNING

Failure to inspect and properly maintain the brakes increases your chance of having an accident.

Inspect the brake system before each use according to the **INSPECTION BEFORE RIDING** section. Follow the **MAINTENANCE SCHEDULE** section to maintain your brake system.

NOTE: Operating in mud, water, sand or other extreme conditions can cause accelerated brake wear. If you operate your motorcycle under these conditions, the brakes must be inspected more often than recommended in the MAINTENANCE SCHEDULE.

Brake Fluid

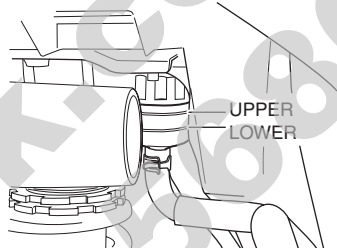
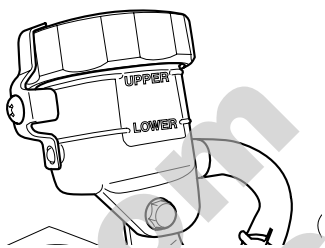

Check the brake fluid level in both the front and rear brake fluid reservoirs. If the level in either reservoir is below the lower mark, inspect for brake pad wear and leaks.

▲ WARNING

Brake fluid is harmful or fatal if swallowed, and harmful if it comes in contact with skin or eyes.

If swallowed, do not induce vomiting. Immediately contact a poison control center or a physician. If brake fluid gets in eyes, flush eyes with water and seek medical attention. Wash thoroughly after handling. Solution can be poisonous to animals. Keep out of the reach of children and animals.

▲ WARNING

Failure to keep the brake fluid reservoir full with proper brake fluid can be hazardous. The brakes may not work correctly without the proper amount and type of brake fluid. This could lead to an accident.

Inspect the brake fluid level before each use. Use only DOT4 brake fluid from a sealed container. Never use or mix different types of brake fluid. If there is frequent loss of fluid, take your motorcycle to a SUZUKI dealer or a qualified mechanic for inspection.

CAUTION

Spilled brake fluid can damage painted surfaces and plastic parts.

Avoid spilling any fluid when filling the reservoir. Wipe up spills immediately.

Brake Pads

FRONT

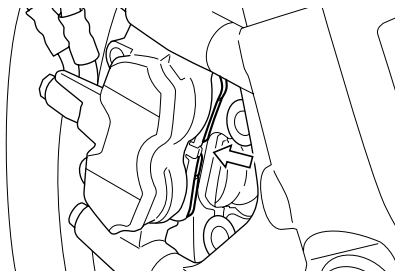

REAR

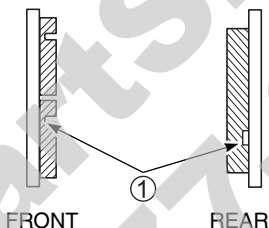
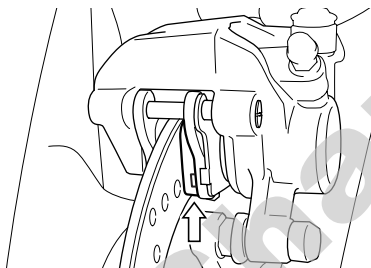

Inspect the front and rear brake pads to see if they are worn down to the grooved wear limit line ①. If a front or rear pad is worn to the grooved wear limit line, both front or both rear pads must be replaced with new ones. After replacing either the front or rear brake pads, the brake lever or pedal must be pumped several times. This will extend the pads to their proper position.

⚠ WARNING

Riding with worn brake pads will reduce braking performance and will increase your chance of having an accident.

Inspect brake pad wear before each use. Ask your SUZUKI dealer or a qualified mechanic to replace brake pads if any pad is worn to the limit.

⚠ WARNING

Failure to extend brake pads after repair or replacement can cause poor braking performance and may result in an accident.

Before riding, “pump” the brake lever/pedal repeatedly until brake pads are pressed against the brake disks and proper lever/pedal stroke and firm feel are restored.

NOTE: Do not squeeze/depress the brake lever/pedal when the pads are not in their positions. It is difficult to push the pistons back and brake fluid leakage may result.

⚠ WARNING

Replacing only one or the two brake pads can result in uneven braking action.

Replace both pads together.

Rear Brake Pedal Adjustment

The rear brake pedal position must be properly adjusted at all times or the disk brake pads will rub against the disk causing damage to the pads and to the disk surface. Adjust the brake pedal position in the following manner:

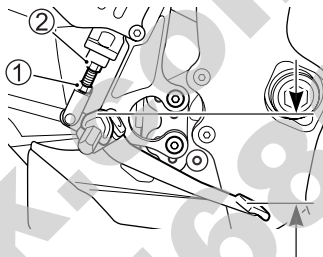

1. Loosen the lock nut ①, and turn the push rod ② to locate the pedal 65 – 75 mm (2.6 – 3.0 in) below the top face of the footrest.
2. Retighten the lock nut ① to secure the push rod ② in the proper position.

CAUTION

An incorrectly adjusted brake pedal may force brake pads to rub against the disk at all times, causing damage to the pads and disk.

Follow the steps in this section to adjust the brake pedal properly.

Rear Brake Light Switch

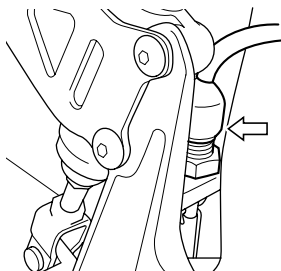

To adjust the brake light switch, hold the switch body and turn the adjuster so that the brake light will come on just before a pressure rise is felt when the brake pedal is depressed.

TIRES

▲ WARNING

Failure to follow these warnings may result in an accident due to tire failure. The tires on your motorcycle form the crucial link between your motorcycle and the road.

Follow these instructions;

- Check tire condition and pressure, and adjust pressure before each ride.
- Avoid overloading your motorcycle.
- Replace a tire when worn to the specified limit, or if you find damage such as cuts or cracks.
- Always use the size and type of tires specified in this owner's manual.
- Balance the wheel after tire installation.
- Read this section of the owner's manual carefully.

WARNING

Failure to perform break-in of the tires could cause tire slip and loss of control.

Use extra care when riding on new tires. Perform proper break-in of the tires referring to the **BREAK-IN** section and avoid hard acceleration, hard cornering, and hard braking for the first 100 miles (160 km).

Tire Pressure and Loading

Proper tire pressure and proper tire loading are important factors. Overloading your tires can lead to tire failure and loss of vehicle control.

Check tire pressure each day before you ride, and be sure the pressure is correct for the vehicle load according to the table below. Tire pressure should only be checked and adjusted before riding, since riding will heat up the tires and lead to higher inflation pressure readings.

Under-inflated tires make smooth cornering difficult, and can result in rapid tire wear. Over-inflated tires cause a smaller amount of tire to be in contact with the road, which can contribute to skidding and loss of control.

NOTE: When you detect drops in tire pressure, check the tire for nails or other punctures, or a damaged wheel rim. Tubeless tires sometimes lose pressure gradually when punctured.

LOAD \ TIRE	SOLO RIDING	DUAL RIDING
FRONT	250 kPa 2.50 kgf/cm ² 36 psi	250 kPa 2.50 kgf/cm ² 36 psi
REAR	290 kPa 2.90 kgf/cm ² 42 psi	290 kPa 2.90 kgf/cm ² 42 psi

Tire Condition and Type

Tire condition and tire type affect motorcycle performance. Cuts or cracks in the tires can lead to tire failure and loss of motorcycle control. Worn tires are susceptible to puncture failures and subsequent loss of motorcycle control. Tire wear also affects the tire profile, changing motorcycle handling characteristics.

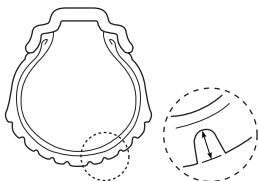

Check the condition of your tires each day before you ride. Replace tires if tires show visual evidence of damage, such as cracks or cuts, or if tread depth is less than 1.6 mm (0.06 in) front, 2.0 mm (0.08 in) rear.

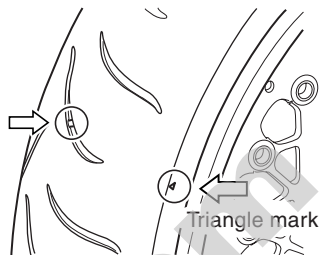

NOTE: The "Triangle mark" mark indicates the place where the wear bars are molded into the tire. When the wear bars contact the road, it indicates that the tire wear limit has been reached.

Whenever you replace a tire, use a tire of the size and type listed below. If you use a different size or type of tire, motorcycle handling may be adversely affected, possibly resulting in loss of motorcycle control.

	FRONT	REAR
SIZE	120/70ZR17M/C (58W)	190/50ZR17M/C (73W)
TYPE	BRIDGESTONE BT016F N	BRIDGESTONE BT016R N

Always balance the wheel after repairing a puncture or replacing the tire. Proper wheel balance is important to avoid variable wheel-to-road contact, and to avoid uneven tire wear.

▲ WARNING

An improperly repaired, installed, or balanced tire can cause loss of control or shorten tire life.

- Ask your SUZUKI dealer or a qualified mechanic to perform tire repair, replacement, and balancing because proper tools and experience are required.
- Install tires according to the rotation direction shown by arrows on the sidewall of each tire.

▲ WARNING

Failure to follow these instructions about tubeless tires may result in an accident due to tire failure. Tubeless tires require different service procedures than tube tires.

- Tubeless tires require an airtight seal between the tire bead and wheel rim. Special tire irons and rim protectors or a specialized tire mounting machine must be used for removing and installing tires to prevent tire or rim damage which could result in an air leak.
- Repair punctures in tubeless tires by removing the tire and applying an internal patch.
- Do not use an external repair plug to repair a puncture since the plug may work loose as a result of the cornering forces experienced by a motorcycle tire.
- After repairing a tire, do not exceed 80 km/h (50 mph) for the first 24 hours, 130 km/h (80 mph) thereafter. This is to avoid excessive heat build-up which could result in a tire repair failure and tire deflation.
- Replace the tire if it is punctured in the sidewall area, or if a puncture in the tread area is larger than 6 mm (3/16 in). These punctures cannot be repaired adequately.

SIDE STAND/IGNITION INTERLOCK SWITCH

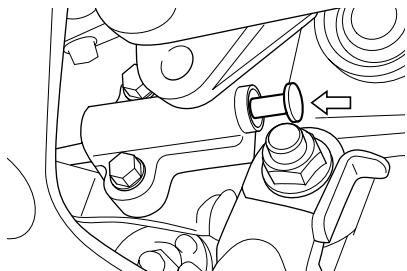

Check the side stand/ignition interlock system for proper operation as follows:

1. Sit on the motorcycle in the normal riding position, with the side stand up.
2. Shift into first gear, hold the clutch in, and start the engine.
3. While continuing to hold the clutch in, move the side stand to the down position.

If the engine stops running when the side stand is moved to the down position, then the side stand/ignition interlock system is working properly. If the engine continues to run with the side stand down and the transmission in gear, then the side stand/ignition interlock switch is not working properly. Have your motorcycle inspected by an authorized Suzuki dealer or a qualified service mechanic.

WARNING

If the side stand/ignition interlock system is not working properly, it is possible to ride the motorcycle with the side stand in the down position. This may interfere with rider control during a left turn.

Check the side stand/ignition interlock system for proper operation before riding. Check that the side stand is returned to its full up position before starting off.

FRONT WHEEL REMOVAL

1. Place the motorcycle on the side stand.

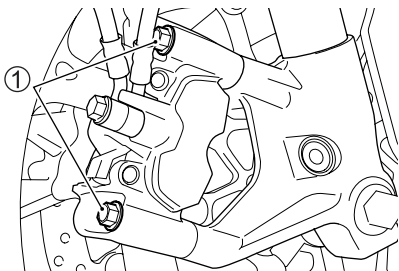

2. Remove both brake calipers from the front forks by removing 2 mounting bolts ① on each of the calipers.

NOTE: Never squeeze the front brake lever with the caliper removed. It is very difficult to force the pads back into the caliper assembly and brake fluid leakage may result.

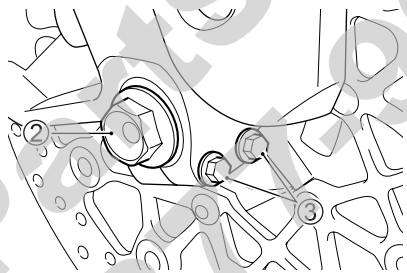

3. Remove the bolt ②.
4. Loosen the axle holder bolts ③.

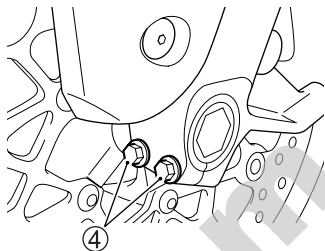

5. Loosen the axle holder bolts ④.
6. Place an accessory service stand or equivalent under the swingarm to help stabilize the rear end.
7. Carefully position a jack under the exhaust pipe and raise until the front wheel is slightly off the ground.

CAUTION

Improper jacking may cause damage to the fairing or oil filter.

Do not apply the jack head to the fairing lower part or the oil filter when jacking up the motorcycle.

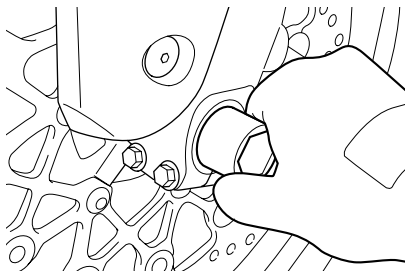

8. Draw out the axle shaft.

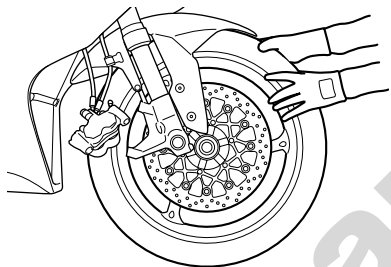

9. Slide the front wheel forward.
10. Put the new wheel in place and insert the axle shaft.
11. Remove the jack and service stand.

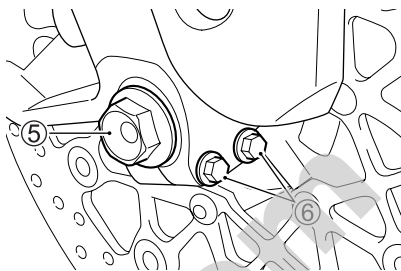

12. Hold the shaft and tighten the bolt ⑤ to the specified torque.
13. Tighten the axle holder bolts ⑥ to the specified torque.
14. Move the steering up and down several times to seat the axle shaft.

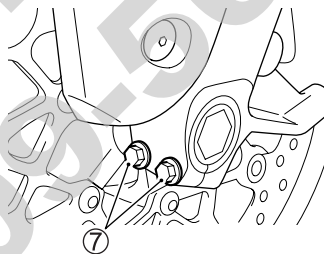

15. Tighten the axle holder bolts ⑦ to the specified torque.
16. Reinstall the brake calipers.
17. After installing the wheel, apply the brake several times to restore the proper lever stroke.

▲ WARNING

Failure to extend brake pads after installing the wheel can cause poor braking performance and may result in an accident.

Before riding, “pump” the brake lever repeatedly until brake pads are pressed against the brake disks and proper lever stroke and firm feel are restored. Also check that the wheel rotates freely.

▲ WARNING

Installing the front wheel in the reverse direction can be hazardous. The tire for this motorcycle is directional. Therefore, the motorcycle may have unusual handling if the wheel is installed incorrectly.

Install the front wheel in the specified direction, as indicated by the arrow on the sidewall of the tire.

▲ WARNING

Failure to torque bolts and nuts properly could lead to an accident.

Torque bolts and nuts to the proper specifications. If you are not sure of the proper procedure, have your authorized SUZUKI dealer or a qualified mechanic do this.

Front axle tightening torque:
100 N·m (10.0 kgf-m, 72.5 lbf-ft)

Front axle holder bolt
tightening torque:
23 N·m (2.3 kgf-m, 16.5 lbf-ft)

Front brake caliper mounting bolt
tightening torque:
39 N·m (3.9 kgf-m, 28.0 lbf-ft)

REAR WHEEL REMOVAL

▲ WARNING

A hot muffler can burn you. The muffler will be hot enough to burn you for some time after stopping the engine.

Wait until the muffler cools to avoid burns.

1. Place the motorcycle on the side stand.

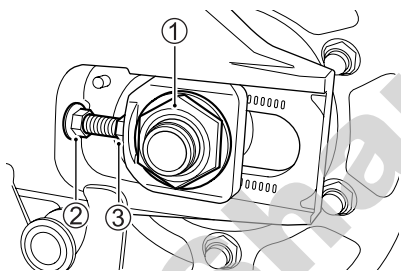

2. Remove the axle nut ①.
3. Place an accessory service stand or an equivalent stand under the swing arm to lift the rear wheel slightly off the ground.
4. Loosen the right and left lock nuts ②. Turn the right and left chain adjuster bolts ③ clockwise.

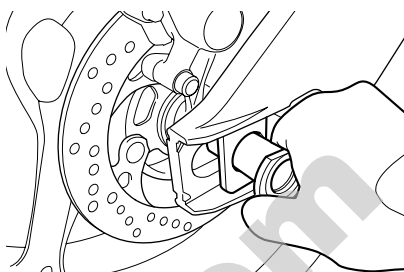

5. Draw out the axle shaft.

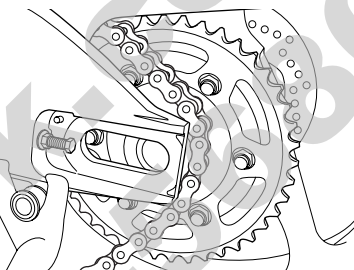

6. With the wheel moved forward, remove the chain from the sprocket.

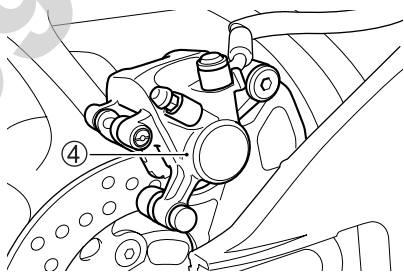

7. Remove the rear brake caliper assembly ④.

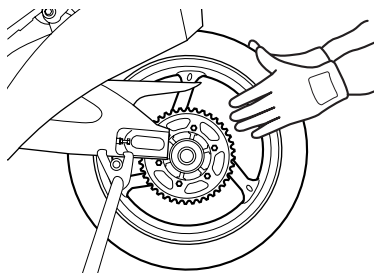

8. Pull the rear wheel assembly rearward.

NOTE: Never depress the rear brake pedal with the rear wheel removed. It is very difficult to force the pads back into the caliper assembly.

9. To replace the wheel reverse the complete sequence listed.
10. Adjust the drive chain slack.
11. After installing the wheel, apply the brake several times and then check that the wheel rotates freely.

⚠ WARNING

Failure to adjust the drive chain and failure to torque bolts and nuts properly could lead to an accident.

- Adjust the drive chain as described in **DRIVE CHAIN ADJUSTMENT** section after installing the rear wheel.
- Torque bolts and nuts to the proper specifications. If you are not sure of the proper procedure, have your authorized **SUZUKI** dealer or a qualified mechanic do this.

Rear axle nut tightening torque:
100 N·m (10.0 kgf-m, 72.5 lbf-ft)

⚠ WARNING

Failure to extend brake pads after installing the wheel can cause poor braking performance and may result in an accident.

Before riding, “pump” the brake pedal repeatedly until brake pads are pressed against the brake disks and proper pedal stroke and firm feel are restored. Also check that the wheel rotates freely.

LIGHT BULB REPLACEMENT

The wattage rating of each bulb is shown in the following chart. When replacing a burned-out bulb, always use the same wattage rating according to the following chart.

CAUTION

Using a light bulb with the wrong wattage rating can cause electrical system damage or shorten bulb life.

Always use the specified light bulb.

Headlight	12V 55W (H11) ... Low beam 12V 65W (H9) ... High beam
Turn signal light	12V 21W × 4
Position light	12V 5W × 2
License plate light	12V 5W

HEADLIGHT

To replace the headlight bulbs, perform the following steps:

Low Beam Bulb

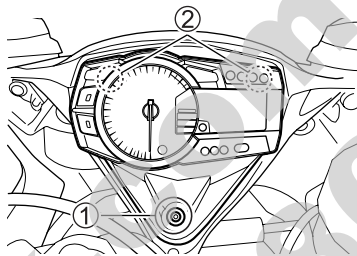

1. Remove the bolt (1). Unhook the hooks (2) to lift the instrument panel.

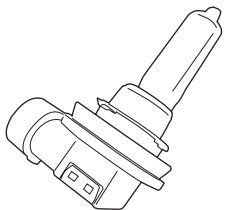
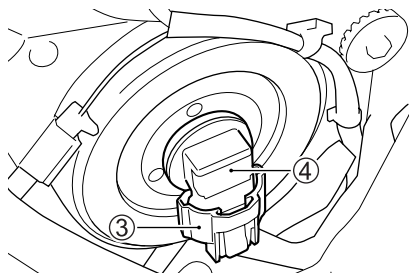

2. Disconnect the coupler ③. Turn the bulb ④ counterclockwise and remove it.

CAUTION

Oil from your skin may damage the headlight bulb or shorten its life.

Grasp the new bulb with a clean cloth.

High Beam Bulb



1. Remove the fasteners. Remove the under cover ①.

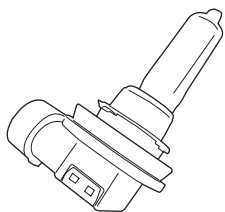
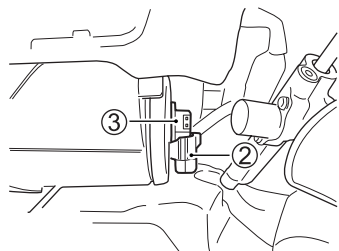

2. Disconnect the coupler ②. Turn the bulb ③ counterclockwise and remove it.

CAUTION

Oil from your skin may damage the headlight bulb or shorten its life.

Grasp the new bulb with a clean cloth.

Headlight Beam Adjustment

The headlight beam can be adjusted both up and down or right and left if necessary.



To adjust the beam up and down:
Turn the adjuster ① clockwise or counterclockwise.

To adjust the beam right and left:
Turn the adjuster ② clockwise or counterclockwise.

POSITION LIGHT

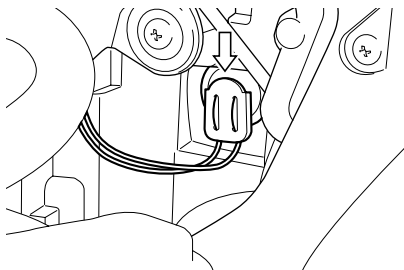

1. Pull out the socket.

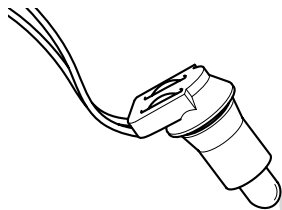

2. Pull off the bulb from the socket.

FRONT TURN SIGNAL LIGHT

To replace the front turn signal light bulb, follow these directions.

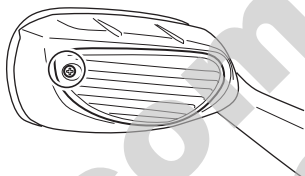

1. Remove the screw and take off the front turn signal assembly.

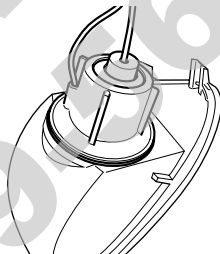

2. Turn the socket counterclockwise and remove it.

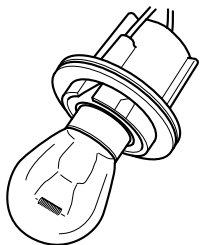

3. Push in the bulb and turn it counterclockwise.

CAUTION

Overtightening the screws when reinstalling the lens may cause the lens to crack.

Tighten the screws only until they are snug.

REAR TURN SIGNAL LIGHT

To replace the rear turn signal light bulb, follow these directions.

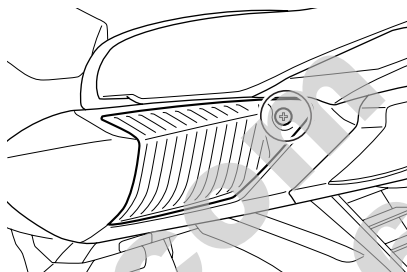

1. Remove the screw and take off the lens.

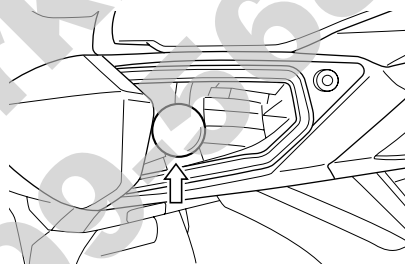

2. Push in on the bulb, turn it to the left, and pull it out.
3. To fit the replacement bulb, push it in and twist it to the right while pushing.

CAUTION

Overtightening the screws when reinstalling the lens may cause the lens to crack.

Tighten the lens screws only until they are snug.

LICENSE PLATE LIGHT

To replace the license plate light bulb, follow the procedure steps:

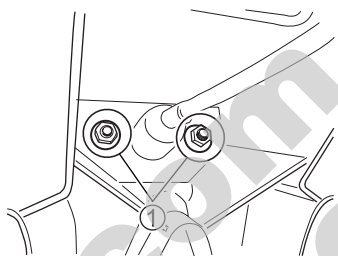

1. Remove the nuts ①.

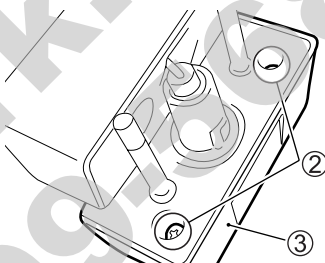

2. Remove the screws ② and take off the cover with the lens ③.

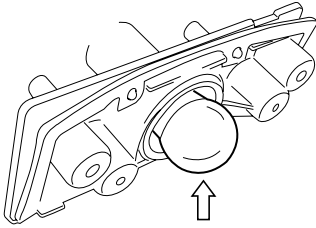

3. Push in on the bulb, twisting it to the left, and pull it out.
4. To fit the replacement bulb, push it in and twist it to the right while pushing.

FUSES

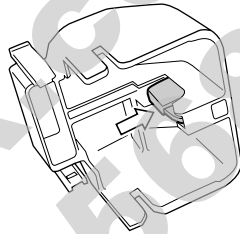

The main fuse is located under the front seat. To access the fuse, remove the front seat by referring to the SEAT LOCK AND HELMET HOLDERS section. One 30A spare fuse is located inside the fuse box cover.

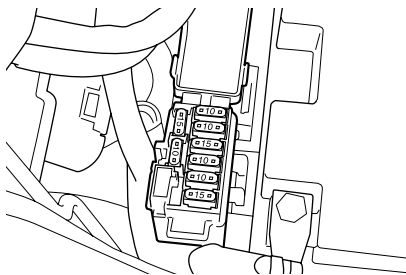

The fuses are located under the front seat. Two spare fuses (one 10A and one 15A) are provided inside the fuse box.

The fuses are designed to open when a circuit overload exists in individual electrical system circuits. If any electrical system fails to operate, then the fuses must be checked.

CAUTION

Installing a fuse of incorrect rating or using aluminum foil or wire instead of a fuse may seriously damage the electrical system.

Always replace a blown fuse with a fuse of the same type and rating. If the new fuse blows in a short time, consult your Suzuki dealer or a qualified mechanic immediately.

Fuse List

- 30A MAIN fuse protects all electrical circuits.
- 10A HEAD-HI fuse protects the headlight high beam and speedometer.
- 10A HEAD-LO fuse protects the headlight low beam.
- 15A IGNITION fuse protects the cooling fan relay, ignition coils, starter relay, fuel pump relay, solenoid, ECU, oxygen sensor, side stand relay and *canister purge solenoid.
- 10A SIGNAL fuse protects the turn signal lights, position lights, taillight, stop lamp, license light and speedometer.
- 10A FUEL fuse protects the speedometer, fuel injectors, fuel pump and ECU.
- 15A FAN fuse protects the cooling fan motor.

* For California

PartShark.com
877-999-5686



TROUBLESHOOTING

FUEL SUPPLY CHECK	8-2
IGNITION SYSTEM CHECK	8-3

TROUBLESHOOTING

This troubleshooting guide is provided to help you find the cause of some common complaints.

CAUTION

Failure to troubleshoot a problem correctly can damage your motorcycle. Improper repairs or adjustments may damage the motorcycle instead of fixing it. Such damage may not be covered under warranty.

If you are not sure about the proper action, consult your Suzuki dealer or a qualified mechanic about the problem.

COMPLAINT: Engine is hard to start or does not start at all.

FUEL SUPPLY CHECK

If the electronic control system indicator displays “FI”, showing signs of trouble in the fuel injection system, take your machine to an authorized Suzuki dealer. Refer to the “INSTRUMENT PANEL” section for an explanation of electronic control system indicator. If the indicator does not display “FI”, make sure there is enough fuel in the fuel tank. If the indicator does not display “FI” and there is enough fuel, the ignition system should be checked.

IGNITION SYSTEM CHECK

1. Remove the spark plug and reattach it to the ignition coil.

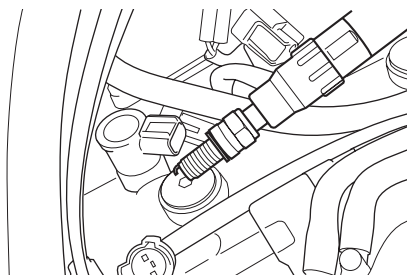

2. Put the engine stop switch in the “ Ω ” position and the ignition switch in the “ON” position. While holding a spark plug with its base firmly against the engine, push the electric starter button. If the ignition system is operating properly, a blue spark should jump across the spark plug gap.
3. If there is no spark, clean the spark plug. Replace it if necessary. Retry the above procedure with the cleaned spark plug or new one.
4. If there is still no spark, take your motorcycle to an authorized Suzuki dealer.

WARNING

Performing the spark test improperly can cause a high voltage electrical shock or an explosion.

Avoid performing this check if you are not familiar with this procedure, or if you have a heart condition or wear a pacemaker. Keep the spark plug away from the spark plug hole during this test.

COMPLAINT: Engine stalls.

1. Make sure there is enough fuel in the fuel tank.
2. If the electronic control system indicator displays “FI”, showing signs of trouble in the fuel injection system, take your machine to an authorized Suzuki dealer. Refer to the “INSTRUMENT PANEL” section for an explanation of the electronic control system indicator.
3. Check the ignition system for intermittent spark.
4. Check the idle speed. The correct idle speed is 1050 – 1250 r/min.

PartShark.com
877-999-5686



STORAGE PROCEDURE AND MOTORCYCLE CLEANING

STORAGE PROCEDURE	9-2
PROCEDURE FOR RETURNING TO SERVICE	9-3
CORROSION PREVENTION	9-3
MOTORCYCLE CLEANING	9-4
INSPECTION AFTER CLEANING	9-6

STORAGE PROCEDURE AND MOTORCYCLE CLEANING

STORAGE PROCEDURE

If your motorcycle is to be left unused for an extended period of time, it needs special servicing requiring appropriate materials, equipment and skill. For this reason, Suzuki recommends that you trust this maintenance work to your Suzuki dealer. If you wish to service the machine for storage yourself, follow the general guidelines below:

MOTORCYCLE

Clean the entire motorcycle. Place the motorcycle on the side stand on a firm, flat surface where it will not fall over.

FUEL

1. Fill the fuel tank to the top with fuel mixed with the amount of gasoline stabilizer recommended by the stabilizer manufacturer.
2. Run the engine for a few minutes until the stabilized gasoline fills the fuel injection system.

ENGINE

1. Pour one tablespoon of motor oil into each spark plug hole. Reinstall the spark plugs and crank the engine a few times.
2. Drain the engine oil thoroughly and refill the crankcase with fresh engine oil all the way up to the filler hole.
3. Cover the air cleaner intake and the muffler outlet with oily rags to prevent humidity from entering.

BATTERY

1. Remove the battery from the motorcycle by referring to the BATTERY section.
2. Clean the outside of the battery with a mild soap and remove corrosion from the terminals and wiring harness.
3. Store the battery in a room above freezing.

TIRES

Inflate tires to the normal pressure.

EXTERNAL

- Spray all vinyl and rubber parts with rubber protectant.
- Spray unpainted surfaces with rust preventative.
- Coat painted surfaces with car wax.

MAINTENANCE DURING STORAGE

Once a month, recharge the battery. The standard charging rate is 1.2A x 5 to 10 hours.

PROCEDURE FOR RETURNING TO SERVICE

1. Clean the entire motorcycle.
2. Remove the oily rags from the air cleaner intake and muffler outlet.
3. Drain all the engine oil. Install a new oil filter and fill the engine with fresh oil as outlined in this manual.
4. Remove the spark plugs. Turn the engine a few times. Reinstall the spark plugs.
5. Reinstall the battery by referring to the BATTERY section.
6. Make sure that the motorcycle is properly lubricated.
7. Perform the INSPECTION BEFORE RIDING as listed in this manual.
8. Start the motorcycle as outlined in this manual.

CORROSION PREVENTION

It is important to take good care of your motorcycle to protect it from corrosion and keep it looking new for years to come.

Important Information About Corrosion

Common causes of corrosion

- Accumulation of road salt, dirt, moisture, or chemicals in hard-to-reach areas.
- Chipping, scratches, and any damage to treated or painted metal surfaces resulting from minor accidents or impacts from stones and gravel.

Road salt, sea air, industrial pollution, and high humidity will all contribute to corrosion.

How to Help Prevent Corrosion

- Wash your motorcycle frequently, at least once a month. Keep your motorcycle as clean and dry as possible.
- Remove foreign material deposits. Foreign material such as road salt, chemicals, road oil or tar, tree sap, bird droppings and industrial fallout may damage your motorcycle's finish. Remove these types of deposits as quickly as possible. If these deposits are difficult to wash off, an additional cleaner may be required. Follow the manufacturer's directions when using these special cleaners.

- Repair finish damage as soon as possible. Carefully examine your motorcycle for damage to the painted surfaces. Should you find any chips or scratches in the paint, touch them up immediately to prevent corrosion from starting. If the chips or scratches have gone through to the bare metal, have a Suzuki dealer make the repair.
- Store your motorcycle in a dry, well-ventilated area. If you often wash your motorcycle in the garage or if you frequently park it inside when wet, your garage may be damp. The high humidity may cause or accelerate corrosion. A wet motorcycle may corrode even in a heated garage if the ventilation is poor.
- Cover your motorcycle. Exposure to mid-day sun can cause the colors in paint, plastic parts, and instrument faces to fade. Covering your motorcycle with a high-quality, “breathable” motorcycle cover can help protect the finish from the harmful UV rays in sunlight, and can reduce the amount of dust and air pollution reaching the surface. Your Suzuki dealer can help you select the right cover for your motorcycle.

MOTORCYCLE CLEANING

Washing the Motorcycle

When washing the motorcycle, follow the instructions below:

1. Remove dirt and mud from the motorcycle with cool running water. You may use a soft sponge or brush. Do not use hard materials which can scratch the paint.
2. Wash the entire motorcycle with a mild detergent or car wash soap using a sponge or soft cloth. The sponge or cloth should be frequently soaked in the soap solution.

CAUTION

Radiator fins can be damaged by spraying high pressure water on them.

Do not spray high pressure water on the radiator fins.

NOTE: Avoid spraying or allowing water to flow over the following places:

- Ignition switch
- Spark plugs
- Fuel tank cap
- Fuel injection system
- Brake master cylinders

CAUTION

High pressure washers and parts cleaner can damage your motorcycle.

Do not use high pressure washers to clean your motorcycle. Do not use parts cleaner to throttle body and fuel injection sensors.

CAUTION

Cleaning with any alkaline or strong acid cleaner gasoline, brake fluid, or any other solvent will damage the motorcycle parts.

Clean only with soft cloth and warm water with mild detergent.

3. Once the dirt has been completely removed, rinse off the detergent with running water.
4. After rinsing, wipe off the motorcycle with a wet chamois or cloth and allow it to dry in the shade.
5. Check carefully for damage to painted surfaces. If there is any damage, obtain "touch-up" paint and "touch-up" the damage following the procedure below:
 - a. Clean all damaged spots and allow them to dry.
 - b. Stir the paint and "touch-up" the damaged spots lightly with a small brush.
 - c. Allow the paint to dry completely.

Windshield Cleaning

Clean the windshield with a soft cloth and warm water with a mild detergent. If scratched, polish with a commercially available plastic polish. Replace the windshield if it becomes scratched or discolored so as to obstruct view. When replacing the windshield, use a Suzuki replacement windshield.

Waxing the Motorcycle

After washing the motorcycle, waxing and polishing are recommended to further protect and beautify the paint.

- Only use waxes and polishes of good quality.
- When using waxes and polishes, observe the precautions specified by the manufacturers.

Special Care for Matte Finish Paint

Do not use polishing compounds or waxes that contain polishing compounds on surfaces which have a matte finish. The use of polishing compounds will change the appearance of the matte finish.

Solid type waxes may be difficult to remove from surfaces with a matte finish.

Excessive rubbing or polishing of a surface with a matte finish will change its appearance.

INSPECTION AFTER CLEANING

For extended life of your motorcycle, lubricate according to "LUBRICATION POINTS" section.

⚠ WARNING

Wet brakes can cause poor braking performance and may lead to an accident.

Avoid a possible accident by expecting longer stopping distances after washing your motorcycle. Apply brakes several times to let heat dry the brake pads or shoes.

Follow the procedures in the "INSPECTION BEFORE RIDING" section to check your motorcycle for any problems that may have arisen during your last ride.

CONSUMER INFORMATION

EMISSION CONTROL WARRANTY	10-2
REPORTING SAFETY DEFECTS	10-2
TAMPERING WITH NOISE CONTROL SYSTEM PROHIBITED	10-3
ON-BOARD MOTORCYCLE COMPUTER DATA INFORMATION	10-4
SERIAL NUMBER LOCATION	10-5
LOCATION OF LABELS	10-6

CONSUMER INFORMATION

EMISSION CONTROL WARRANTY

Suzuki Motor Corporation warrants to the ultimate purchaser and each subsequent purchaser that this vehicle is designed, built, and equipped so as to conform at the time of sale with all U.S. emission standards applicable at the time of manufacture, and that it is free from defects in materials and workmanship which would cause it not to meet these standards within its useful life. Useful life is defined for each class of motorcycle as 5 years or the corresponding number of kilometers (miles) shown in the chart below, whichever occurs first.

Vehicle class	Engine displacement	Useful Life Distance
Class I	50 to 169 cc	12000 km (7456 miles)
Class II	170 to 279 cc	18000 km (11185 miles)
Class III	280 cc and over	30000 km (18641 miles)

Failures, other than those resulting from defects in material or workmanship, which arise solely as a result of owner abuse and/or lack of proper maintenance are not covered by the warranty.

REPORTING SAFETY DEFECTS

If you believe that your vehicle has a defect which could cause a crash or could cause injury or death, you should immediately inform the National Highway Traffic Safety Administration (NHTSA) in addition to notifying American Suzuki Motor Corp.

If NHTSA receives similar complaints, it may open an investigation, and if it finds that a safety defect exists in a group of vehicles, it may order a recall and remedy campaign. However, NHTSA cannot become involved in individual problems between you, your dealer, or American Suzuki Motor Corp.

To contact NHTSA, you may either call the Vehicle Safety Hot Line toll-free 1-888-327-4236 (TTY: 1-800-424-9153); go to <http://www.safercar.gov>; or write to: Administrator, NHTSA, 400 Seventh Street, SW., Washington DC 20590. You can also obtain other information about motor vehicle safety from <http://www.NHTSA.gov>.

To contact American Suzuki, owners in the continental United States can call toll-free 1-800-444-5077, or write to: American Suzuki Motor Corporation Motorcycle Customer Service P.O. Box 1100, Brea, CA 92822-1100.

For owners outside the continental United States, please refer to the distributor's address listed on your Warranty Information brochure.

TAMPERING WITH NOISE CONTROL SYSTEM PROHIBITED

Federal law prohibits the following acts or the causing thereof;

1. The removal or rendering inoperative by any person other than for purposes of maintenance, repair, or replacement, of any device or element of design incorporated into any new vehicle for the purpose of noise control prior to its sale or delivery to the ultimate purchaser or while it is in use, or
2. The use of the vehicle after such device or element of design has been removed or rendered inoperative by any person.

Among those acts presumed to constitute tampering are the acts listed below:

- Removing or puncturing the muffler, baffles, header pipes, screen type spark arrester (if equipped) or any other component which conducts exhaust gases

- Replacing the exhaust system or muffler with a system or muffler not marked with the same model specific code as the code listed on the Motorcycle Noise Emission Control Information label, and certified to appropriate EPA noise standards
- Removing or puncturing the air cleaner case, air cleaner cover, baffles, or any other component which conducts intake air.

Whenever replacing parts on your motorcycle, Suzuki recommends that you use genuine Suzuki replacement parts or their equivalent.

ON-BOARD MOTORCYCLE COMPUTER DATA INFORMATION

Your motorcycle is equipped with on-board computer systems which monitor and control several aspects of motorcycle performance, including the following:

- Emission-related components and engine parameters such as engine speed and throttle position are monitored to provide emission control and to provide optimum fuel economy. Your motorcycle also has an on-board diagnostic system which monitors and records information about emission-related malfunctions.

Some information may be stored by the on-board computer when malfunctions occur. This stored information can assist technicians in repairing the motorcycle. To read the stored information, special equipment is needed and access to the motorcycle or storage device is required. In addition, once SUZUKI collects or receives data, SUZUKI may use the data for research conducted by SUZUKI, make the data available for outside research if need is shown and confidentiality is assured, or make summary data which does not identify specific motorcycles available for outside research.

Others, such as law enforcement personnel, may have access to the special equipment that can read the information if they have access to the motorcycle or storage device.

SERIAL NUMBER LOCATION

You need to know the frame and engine serial numbers to get title documents for your motorcycle. You also need these numbers to help your dealer when you order parts.

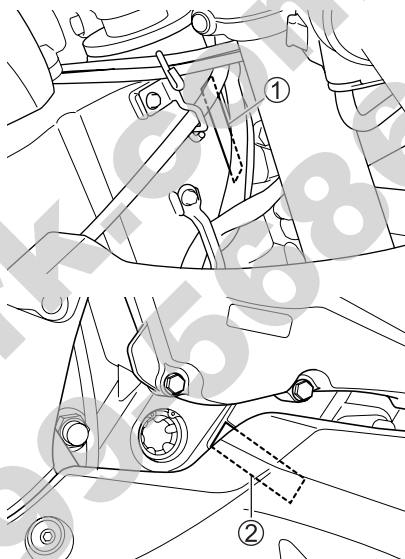

The frame number ① is stamped on the steering head as shown in the illustration. The engine serial number ② is stamped on the crankcase assembly.

Write down the serial numbers here for your future reference.

Frame No.:

Engine No.:

LOCATION OF LABELS

Read and follow all of the warnings labeled on your motorcycle. Make sure you understand all of the labels. Keep the labels on your motorcycle. Do not remove them for any reason.

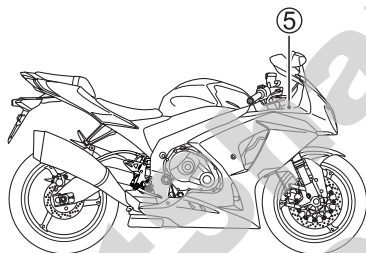
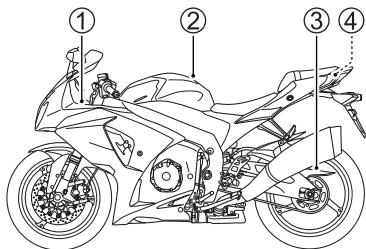

①

▲ WARNING

Do not carry any objects in the space behind the fairing or on the fairing support bars.

Objects placed in these area can interfere with steering and can cause loss of control.

②

▲ WARNING

Failure to follow these safety precautions may increase your risk of injury:

- Wear a helmet, eye protection, and bright protective clothing.
- Don't ride after consuming alcohol or other drugs.
- Slow down on slippery surfaces, unfamiliar terrain, or when visibility is reduced.
- Read owner's manual carefully.

③

▲ WARNING		COLD TIRE PRESSURE			SOLO RIDING			DUAL RIDING		
			kPa	kgf/cm ²	psi	kPa	kgf/cm ²	psi		
<ul style="list-style-type: none"> • Check tire condition, wear, and cold tire pressure before each ride. • Replace only with TUBELESS tires of listed size and type. • Read owner's manual for more information. 		FRONT			250	2.50	36	250	2.50	36
		REAR			290	2.90	42	290	2.90	42
		TIRE SIZE		120/70ZR17M/C (58W)			190/50ZR17M/C (73W)			
TYPE	BRIDGESTONE	BT016F N			BT016R N					

④

The owner's manual contains important safety information and instructions which should be read carefully before operating the vehicle. If the vehicle has been resold, obtain the owner's manual from the previous owner or contact your local SUZUKI dealer for assistance.

⑤

▲ WARNING
<ul style="list-style-type: none"> • Keep windshield clean at all times. • Clean only with a soft cloth and warm water with a mild detergent. • Minor scratches may be removed by polishing with a commercially available plastic polish. Make sure the plastic polish does not contain an abrasive compound, as it may cause permanent scratches. • Replace windshield if it becomes scratched or discolored so as to interfere with view. • Avoid using any alkaline or strong acid cleaner, gasoline, brake fluid, or any other solvent. • When replacing windshield, use Suzuki replacement windshield.

SPECIFICATIONS

DIMENSIONS AND CURB MASS

Overall length	2045 mm (80.5 in)
Overall width.....	720 mm (28.3 in)
Overall height	1130 mm (44.5 in)
Wheelbase	1405 mm (55.3 in)
Ground clearance.....	130 mm (5.1 in)
Seat height	810 mm (31.9 in)
Curb mass	205 kg (452 lbs)

ENGINE

Type.....	Four-stroke, liquid-cooled, DOHC
Number of cylinders	4
Bore.....	74.5 mm (2.933 in)
Stroke	57.3 mm (2.256 in)
Displacement.....	999 cm ³ (61.0 cu. in)
Compression ratio	12.8 : 1
Fuel system	Fuel injection
Air cleaner	Paper element
Starter system	Electric
Lubrication system	Wet sump

DRIVE TRAIN

Clutch	Wet multi-plate type
Transmission	6-speed constant mesh
Gearshift pattern	1-down, 5-up
Primary reduction ratio	1.617 (76/47)
Gear ratios, Low	2.562 (41/16)
2nd.....	2.052 (39/19)
3rd.....	1.714 (36/21)
4th.....	1.500 (36/24)
5th.....	1.360 (34/25)
Top	1.269 (33/26)
Final reduction ratio.....	2.470 (42/17)
Drive chain	DID50VAZ, 114 links

CHASSIS

Front suspension.....	Inverted telescopic, coil spring, oil damped
Rear suspension	Link type, coil spring, oil damped
Front fork stroke	125 mm (4.9 in)
Rear wheel travel.....	130 mm (5.1 in)
Steering angle	27° (right and left)
Caster.....	23° 45'
Trail.....	98 mm (3.86 in)
Turning radius.....	3.4 m (11.2 ft)
Front brake	Disk brake, twin
Rear brake.....	Disk brake
Front tire size	120/70ZR17M/C (58W), tubeless
Rear tire size	190/50ZR17M/C (73W), tubeless

ELECTRICAL

Ignition type	Electronic ignition (Transistorized)
Spark plug	NGK CR9EIA-9 or DENSO IU27D
Battery	12V 36.0 kC(10 Ah)/10 HR
Generator	Three-phase A.C. generator
Fuse	30/10/10/15/10/10/15A
Headlight	12V 55W (H11) + 12V 65W (H9)
Turn signal light	12V 21W
License plate light	12V 5W
Brake light/Taillight	LED
Position light	12V 5W
Speedometer light	LED
Tachometer light	LED
Neutral indicator light	LED
High beam indicator light	LED
Turn signal indicator light	LED
Fuel level indicator light	LED
Oil pressure/	
Coolant temperature indicator light	LED
Electronic control system indicator light	LED
Engine RPM indicator light	LED

CAPACITIES

Fuel tank	17.5 L (4.6 US gal)
	16.5 L (4.4 US gal) ... California model
Engine oil, oil change	2800 ml (3.0 US qt)
With filter change	3300 ml (3.5 US qt)
Coolant	2.8 L (3.0 US qt)

INDEX

- A**
ACCESSORIES AND
LOADING 1-5
ACCESSORY USE 6-2
AIR CLEANER 7-9
- B**
BATTERY 7-7
BE EXTRA SAFETY-
CONSCIOUS ON BAD
WEATHER DAYS..... 1-5
BE STREET SMART..... 1-6
BRAKES..... 7-28
BREAK-IN 4-2
- C**
CARRYING A
PASSENGER..... 1-6,5-7
CLUTCH
ADJUSTMENT 7-22
CONCLUSION 1-6
CORROSION
PREVENTION..... 9-3
- D**
DRIVE CHAIN 7-24
- E**
EMISSION CONTROL
WARRANTY 10-2
ENGINE COOLANT 7-22
ENGINE COOLANT
SOLUTION 2-6
ENGINE IDLE SPEED
INSPECTION..... 7-20
ENGINE OIL 2-4,7-16
- F**
FOOTRESTS AND
GEARSHIFT LEVER
POSITION CHANGE 3-36
FRONT WHEEL
REMOVAL 7-37
FUEL 2-2
FUEL HOSE 7-21
FUEL SUPPLY CHECK..... 8-2
FUEL TANK CAP 3-27
FUSES..... 7-48
- G**
GEARSHIFT LEVER 3-28

I	
IF A COLLISION IS IMMINENT, DO SOMETHING	1-3
IF YOU DON'T HAVE A HELMET, BUY A HELMET AND WEAR IT EVERY TIME YOU RIDE	1-2
IGNITION SWITCH	3-5
IGNITION SYSTEM CHECK.....	8-3
INSPECTION AFTER CLEANING	9-6
INSPECTION BEFORE RIDING.....	1-5,4-3
INSTRUMENT PANEL.....	3-8

K	
KEY	3-5
KNOW YOUR LIMITS	1-4

L	
LEFT HANDLEBAR.....	3-22
LIGHT BULB REPLACEMENT	7-42
LOCATION OF LABELS	10-6
LOCATION OF PARTS	3-2
LUBRICATION POINTS.....	7-6

M	
MAINTENANCE SCHEDULE	7-2
MODIFICATION	6-4
MOST ACCIDENTS CAN BE AVOIDED	1-2
MOTORCYCLE CLEANING	9-4
MOTORCYCLE SAFETY FOUNDATION'S "RIDING TIPS AND PRACTICE GUIDE" HANDBOOK (FOR OWNERS IN USA)	1-6

N	
NOTICE	7-2

O	
ON-BOARD MOTORCYCLE COMPUTER DATA INFORMATION	10-4

P	
PRACTICE AWAY FROM TRAFFIC	1-5
PROCEDURE FOR RETURNING TO SERVICE.....	9-3

R		
REAR BRAKE PEDAL	3-28	
REAR WHEEL		
REMOVAL.....	7-40	
REPORTING SAFETY DEFECTS.....	10-2	
RIDING ON HILLS	5-5	
RIGHT HANDLEBAR	3-25	
S		
SEAT LOCK AND HELMET HOLDERS	3-29	
SERIAL NUMBER LOCATION.....	10-5	
SIDE STAND.....	3-31	
SIDE STAND/IGNITION INTERLOCK SWITCH.....	7-36	
SPARK PLUGS.....	7-12	
SPECIAL SITUATIONS REQUIRE SPECIAL CARE	1-4	
STARTING OFF.....	5-3	
STARTING THE ENGINE.....	5-2	
STEERING DAMPER MAINTENANCE	7-5	
STOPPING AND PARKING	5-5	
STORAGE PROCEDURE	9-2	
SUSPENSION ADJUSTMENT	3-32	
T		
TAMPERING WITH NOISE CONTROL SYSTEM PROHIBITED.....	10-3	
THROTTLE CABLE PLAY	7-21	
TIRES.....	7-32	
TOOLS	7-5	
U		
USING THE TRANSMISSION	5-4	

PartShark.com
877-999-5686



PartShark.com
877-999-5686



WARNING

Failure to follow these safety precautions may increase your risk of injury:

- Wear a helmet, eye protection, and bright protective clothing.
- Don't ride after consuming alcohol or other drugs.
- Slow down on slippery surfaces, unfamiliar terrain, or when visibility is reduced.
- Read owner's manual carefully.



* 9 9 0 1 1 - 4 7 H 5 0 - 0 3 A *

SUZUKI MOTOR CORPORATION

Part No. 99011-47H50-03A December, 2008 EN 

K9

Printed in Japan